



LEANTEC ROBOT EMPOWER CNC APPLICATION



LEANTEC
INTELLIGENCE

LEANTEC

LEANTEC ROBOT EMPOWER CNC APPLICATION



CONTENT

Company Profile / 01

Robot Products / 03

Flexible Robot Cell Products / 43

Handling Peripheral Devices / 47

Robot Applications / 55

Robot Controllers / 61

System Functions / 63

Leantec Cloud Product / 65

ABOUT LEANTEC

29⁺

29-year Experience

1

All in 1 Service

50⁺

50+ Service Locations

NO.1

PC base No.1

Syntec' 29-year experience in the motion control R&D and service PC base No.1

Integrated automation system one-stop service

Provide automation products & overall on-line industrial solutions, including both software and hardware

50+ Global service stations

Taiwan team independent research and development with the leading strength and cooperation with multi-brands

Complete ecosystem to ensure rapid integration

Leantec Intelligence Co., Ltd. (hereinafter referred to as "**Leantec Intelligence**") was established in 2018 and funded by Syntec Group. **Leantec Intelligence** has always been committed to providing manufacturing enterprises with integrated solutions for smart manufacturing based on the Syntec control technology. The core businesses include industrial robots, cloud products (to serve smart clouds and produce smart clouds), automation system integration, various electromechanical modules and smart manufacturing supporting accessories (e.g. smart edge, smart gripper and so on). Furthermore, it aims to help companies improve their production efficiency and product quality and promote industrial upgrading.

Founded in 1995, Syntec Group has long been engaged in the research, development and manufacturing of software and hardware technology for controllers in the field of machine tools and automation tools. It is among the most influential controller brands in the Asia-Pacific market.

Leantec Intelligence, a practitioner of the intelligent manufacturing of the Syntec Group, has attracted professionals from the Syntec Group and intelligent manufacturing-related industries and is committed to providing customers with complete and professional solutions based on our understanding and accumulated knowledges in the machine tool industry and intelligent manufacturing field. Meanwhile, we aim to help enterprises achieve informatization, automation and intelligence, improve their efficiency and gain more market competition.

Our visions: Most trustworthy electronic control partner

Our missions: Complete intelligent factory solution



ROBOT INTRODUCTION

Robot Serial Products

LEANTEC ROBOT

EMPOWER CNC APPLICATION



LEANTEC
LEANTEC INTELLIGENCE

LEANTEC

LEANTEC INTELLIGENCE



Robot Products

R Series

High-precision, high-speed, compact and small footprint design. With high IP rating, the robot is protected against cutting fluid and can be installed inside a machine. It is recommended for high-precision tool grinder, pick and place applications.



Type R	Payload(kg)	Reach(mm)	Pos.rep(mm)	Mounting	Protection	Axes	Remark
LA580-4H	4	580	±0.02	Floor, Upside-down, Angle	IP67	6	Hollow wrist, optional no electric cabinet
LA707-7H	7	707	±0.02	Floor, Upside-down, Angle	IP67	6	Hollow wrist, optional no electric cabinet
LA906-7	7	906	±0.03	Floor, Upside-down, Angle	IP67	6	Standard, optional no electric cabinet
LA1206-10	10	1206	±0.05	Floor, Upside-down, Angle	IP54	6	Standard, optional no electric cabinet
LA1813-25	25	1813	±0.05	Floor, Upside-down, Angle	Wrist part IP67 Base part IP65	6	Standard
LA1813-35	35	1813	±0.05	Floor, Upside-down, Angle	Wrist part IP67 Base part IP65	6	Standard

C Series

High payload capacity and long reach. It is well suited for loading and unloading lathe/milling machines. With the additional application packages, it can meet the requirements of stamping, palletizing, polishing, welding, and cutting industries.



Type C	Payload(kg)	Reach(mm)	Pos.rep(mm)	Mounting	Protection	Axes	Remark
LA1468-10	10	1468	±0.05	Floor, Upside-down, Angle	IP54	6	Standard
LA1717-20	20	1717	±0.05	Floor, Upside-down, Angle	IP54	6	Standard
LA2000-8	8	2000	±0.05	Floor, Upside-down, Angle	IP54	6	Standard
LA2100-60	60	2100	±0.2	Floor	IP54	6	Standard

K Series

High-speed, High-precision, and high protection. Provide a variety of installation methods suitable for complex applications with high-precision requirements, such as handling, grinding, pick and place, welding and other industries.



Type K	Payload(kg)	Reach(mm)	Pos.rep(mm)	Mounting	Protection	Axes	Remark
LA1460-13	13	1460	±0.03	Floor, Upside-down	IP67	6	Standard
LA1725-20	20	1725	±0.04	Floor, Upside-down	Wrist part IP67 Base part IP65	6	Standard

H Series



Collaborative six-axis robot, compact, lightweight, and high IP rating. Compliant with ISO 15066 collaborative safety standards, which ensures operator safety without the need for safety fences. It is ideal for applications, such as handling, assembly, and loading/unloading where human-robot collaboration is required.

Type H	Payload(kg)	Reach(mm)	Pos.rep(mm)	Mounting	Protection	Axes	Remark
LC800-5	5	800	±0.02	Floor, Upside-down, Angle	IP66	6	Standard
LC1000-10	10	1000	±0.03	Floor, Upside-down, Angle	IP66	6	Standard
LC1300-15	15	1300	±0.05	Floor, Upside-down, Angle	IP66	6	Standard

Y Series



High-precision, high-speed, lightweight, compact and small footprint design, suitable for occasions with high-precision requirements and small movement space, such as handling, palletizing, assembly, 3C and other industries.

Type Y	Payload(kg)	Reach(mm)	Pos.rep(mm)			Mounting	Protection	Axes	Remark
			J1/J2(mm)	J3(mm)	J4(°)				
LS400-3	3	400	±0.01	±0.01	±0.01	Floor	IP20	4	Optional no electric cabinet
LS600-6	6	600	±0.02	±0.01	±0.01	Floor	IP54	4	Optional no electric cabinet
LS900-10	10	900	±0.02	±0.01	±0.01	Floor	IP20	4	Optional no electric cabinet

R Series 4KG

LA580-4H Hollow Wrist Type



PRODUCT FEATURES

- High-speed and high-precision with $\pm 0.02\text{mm}$ position repeatability
- Equipped with 16/16 I/O and is easily expandable for more complex applications
- Standard IP67 proved long term operation in harsh environment
- Equipped with 4 quick pneumatic connections and 8 I/O bus connections
- Wrist Model allows pneumatic connections and I/O sensor cables be installed from the base of the flange for easy cable management
- Provide 3 mounting methods: Floor, Upside-down, and Angle mount
- Compact and small footprint design. It's suitable for light payload operations and narrow workspace

MAIN APPLICATIONS

Handling

Loading/Unloading

Grinding

Assembling

Palletizing

Others

R Series 7KG

LA707-7H Hollow Wrist Type



PRODUCT FEATURES

- High-speed and high-precision with $\pm 0.02\text{mm}$ position repeatability
- Equipped with 16/24 I/O and is easily expandable for more complex applications
- Standard IP67 proved long term operation in harsh environment
- Equipped with 4 quick pneumatic connections and 8 I/O bus connections
- Hollow wrist type is selectable. It could let air pipeline and IO sensor wire internally routing from base to wrist frange, which could effectively enhance the gripper design wire winding
- Provide 3 mounting methods: Floor, Upside-down, and Angle mount
- Compact and small footprint design. It's suitable for light payload operations and narrow workspace

MAIN APPLICATIONS

Loading/unloading

Handling

Assembling

Palletizing

Others



Robot Work Envelope

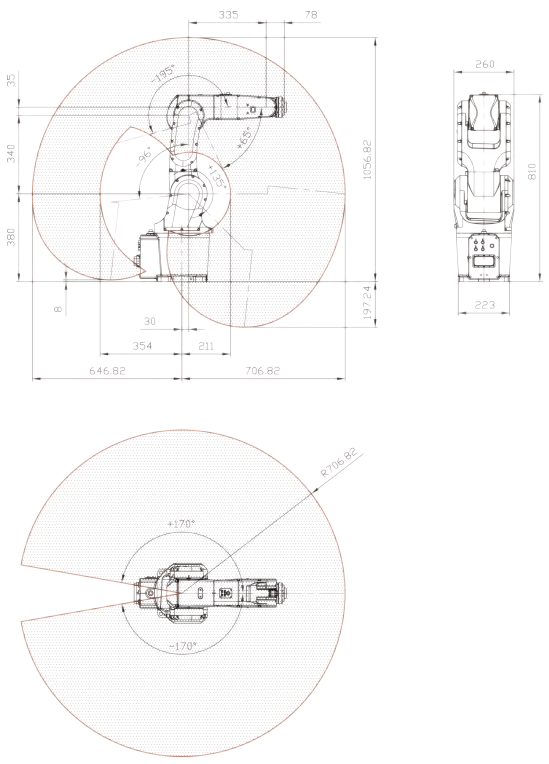

Robot Base Dimension

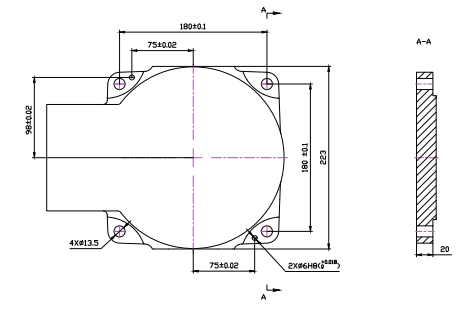

Robot Flange Dimension

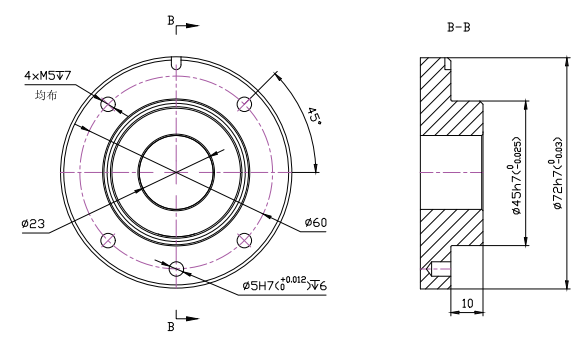

PRODUCT PARAMETERS

No. Control Axes	6	
Max Load Capacity	7	
Max. Reach (mm)	707	
Pos.rep(mm)	±0.02	
Motion Range (°)	J1 Axis	±170
	J2 Axis	+135/-96
	J3 Axis	+65/-195
	J4 Axis	±170
	J5 Axis	±120
	J6 Axis	±360
Max. Speed* (°/s)	J1 Axis	440
	J2 Axis	355
	J3 Axis	440
	J4 Axis	480
	J5 Axis	450
	J6 Axis	900

Motor Output (kw)	J1 Axis	0.75	
	J2 Axis	0.75	
	J3 Axis	0.4	
	J4 Axis	0.2	
	J5 Axis	0.1	
	J6 Axis	0.1	
Weight (kg)	≈50		
Installation	Floor, Upside-down, Angle		
Levels of protection	IP67		
Ambient temperature / Humidity / Vibration	Ambient temperature: 0-45°C Ambient humidity: Normally 20-80%RH or less (No dew, nor frost allow) Short term 90 %RH or less (within one month) Vibration acceleration: 4.9 m/s (0.5G) or less		
Electronic Control Box Specification	Power Supply	Single Phase 200-230VAC 50Hz/60Hz	
	Size	Standard	480mm x 500mm x 280mm
		Optional	330mm x 330mm x 90mm

R Series 7KG

LA906-7 Long arm type



PRODUCT FEATURES

- High-speed and high-precision with $\pm 0.02\text{mm}$ position repeatability
- Equipped with 16/24 I/O and is easily expandable for more complex applications
- Standard IP67 proved long term operation in harsh environment
- Equipped with 4 quick pneumatic connections and 8 I/O bus connections
- Hollow wrist type is selectable. It could let air pipeline and IO sensor wire internally routing from base to wrist frange, which could effectively enhance the gripper design wire winding
- Provide 3 mounting methods: Floor, Upside-down, and Angle mount
- Compact and small footprint design. It's suitable for light payload operations and narrow workspace

MAIN APPLICATIONS

Loading/unloading

Handling

Assembling

Palletizing

Others



Robot Work Envelope

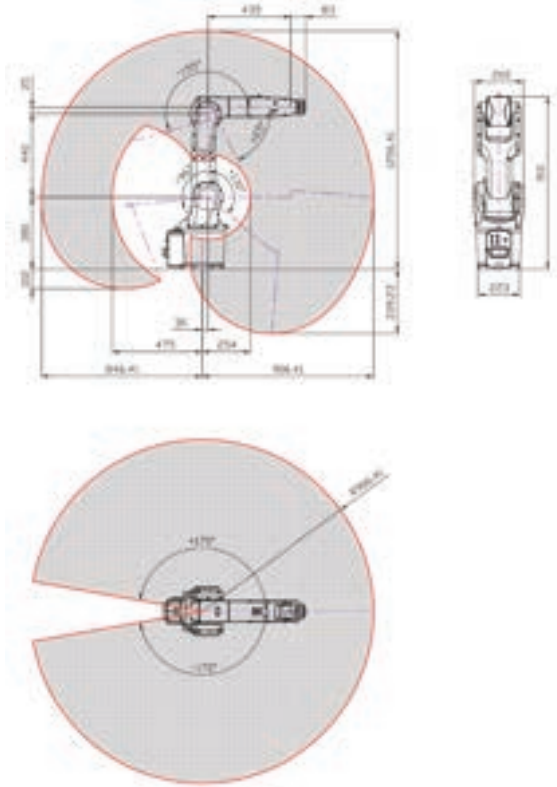

Robot Base Dimension

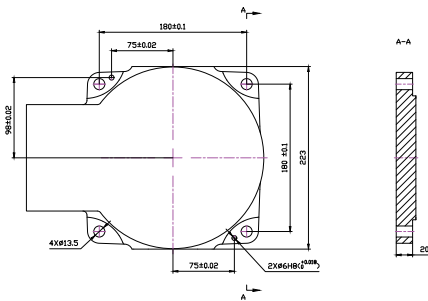

Robot Flange Dimension

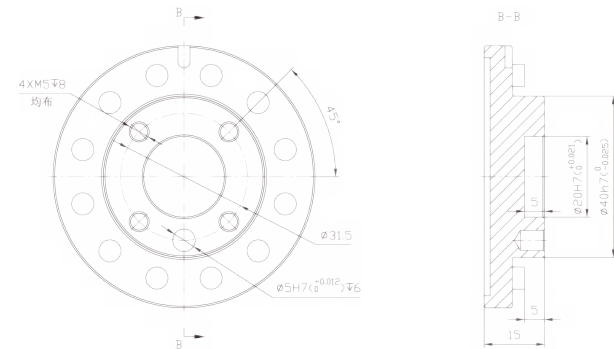

R
C
K
H
Y
Series

PRODUCT PARAMETERS

No. Control Axes		6
Max Load Capacity		7
Max. Reach (mm)		906
Pos.rep(mm)		±0.03
Motion Range (°)	J1 Axis	±170
	J2 Axis	+130/-96
	J3 Axis	+65/-195
	J4 Axis	±170
	J5 Axis	±120
	J6 Axis	±360
Max. Speed* (° /s)	J1 Axis	355
	J2 Axis	355
	J3 Axis	355
	J4 Axis	480
	J5 Axis	450
	J6 Axis	705

Motor Output (kw)	J1 Axis	0.75	
	J2 Axis	0.75	
	J3 Axis	0.4	
	J4 Axis	0.2	
	J5 Axis	0.1	
	J6 Axis	0.1	
Weight (kg)	≈52		
Installation	Floor, Upside-down, Angle		
Levels of protection	IP67		
Ambient temperature / Humidity / Vibration	Ambient temperature: 0~45°C Ambient humidity: Normally 20-80%RH or less (No dew, nor frost allow) Short term 90 %RH or less (within one month) Vibration acceleration: 4.9 m/s (0.5G) or less		
Electronic Control Box Specification	Power Supply	Single Phase 200-230VAC 50Hz/60Hz	
	Size	Standard	480mm X 500mm X 280mm
		Optional	330mm X 330mm X 90mm

R Series 10KG

LA1206-10



PRODUCT FEATURES

- Wider range of motion, high-speed and high-precision with $\pm 0.05\text{mm}$ position repeatability
- Equipped with 16/24 I/O and is easily expandable for more complex applications
- Equipped with 4 quick pneumatic connections and 8 I/O bus connections
- Provide 3 mounting methods: Floor, Upside-down, and Angle mount
- Compact and small footprint design. It's suitable for light payload operations and narrow workspace

MAIN APPLICATIONS

Loading/unloading

Handling

Grinding

Assembling

Palletizing

Others



Robot Work Envelope

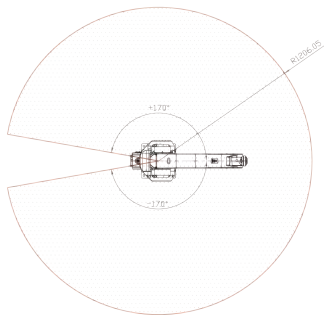
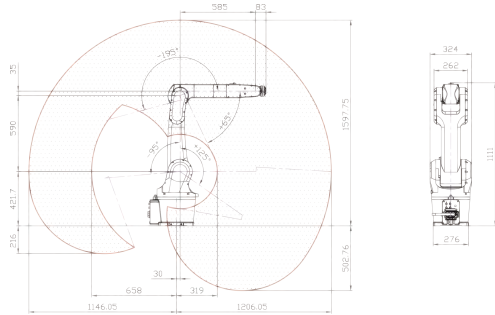

Robot Base Dimension

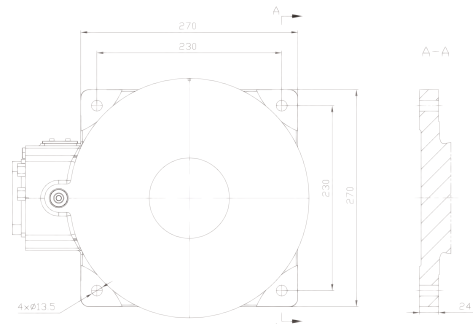

Robot Flange Dimension

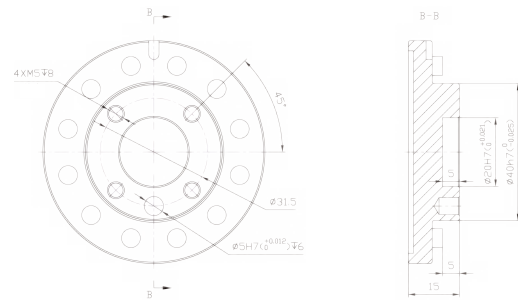

PRODUCT PARAMETERS

No. Control Axes		6
Max Load Capacity		10
Max. Reach (mm)		1206
Pos.rep(mm)		±0.05
Motion Range (°)	J1 Axis	±170
	J2 Axis	+125/-95
	J3 Axis	+65/-195
	J4 Axis	±170
	J5 Axis	±120
	J6 Axis	±360
Max. Speed* (° /s)	J1 Axis	297
	J2 Axis	223
	J3 Axis	220
	J4 Axis	480
	J5 Axis	360
	J6 Axis	705

Motor Output (kw)	J1 Axis	1	
	J2 Axis	1	
	J3 Axis	0.4	
	J4 Axis	0.2	
	J5 Axis	0.1	
	J6 Axis	0.1	
Weight (kg)		≈76	
Installation		Floor, Upside-down, Angle	
Levels of protection		IP54	
Ambient temperature / Humidity / Vibration		Ambient temperature: 0~45°C Ambient humidity: Normally 20-80%RH or less (No dew, nor frost allow) Short term 90 %RH or less (within one month) Vibration acceleration: 4.9 m/s (0.5G) or less	
Electronic Control Box Specification	Power Supply	Single Phase 200-230VAC 50Hz/60Hz	
	Size	Standard	480mm X 500mm X 280mm
		Optional	330mm X 330mm X 90mm

R Series 25KG

LA1813-25



PRODUCT FEATURES

- High-speed and high-precision with $\pm 0.05\text{mm}$ position repeatability
- Equipped with 16/24 I/O and is easily expandable for more complex applications
- Standard IP65 (wrist IP67) proved long term operation in harsh environment
- Equipped with 2 quick pneumatic connections and 24 I/O bus connections
- Provides 1~3 pneumatic valves suitable for grippers in handling and loading/unloading applications
- Provide 3 mounting methods: Floor, Upside-down, and Angle mount

MAIN APPLICATIONS

Loading/unloading

Handling

Grinding

Assembling

Palletizing

Others

Robot Work Envelope

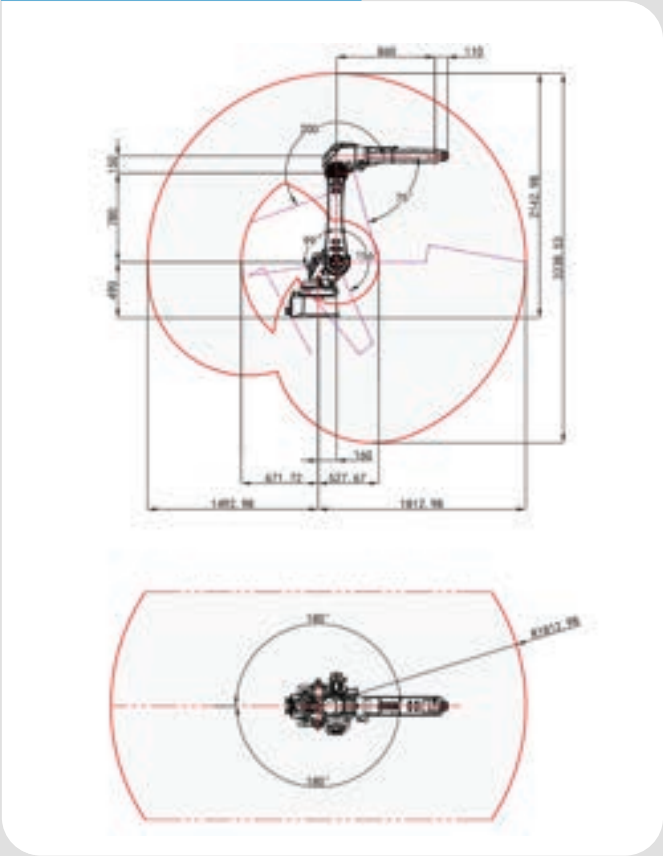

Robot Base Dimension

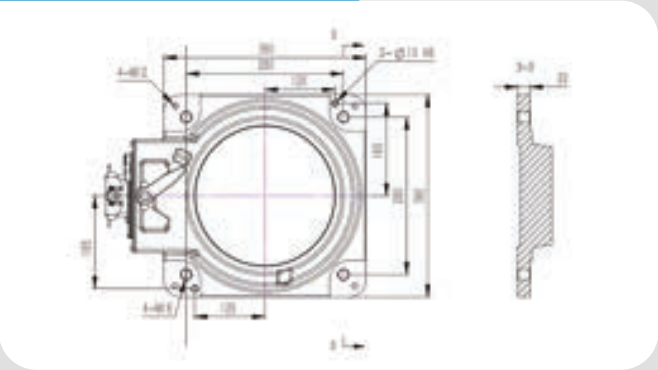

Robot Flange Dimension

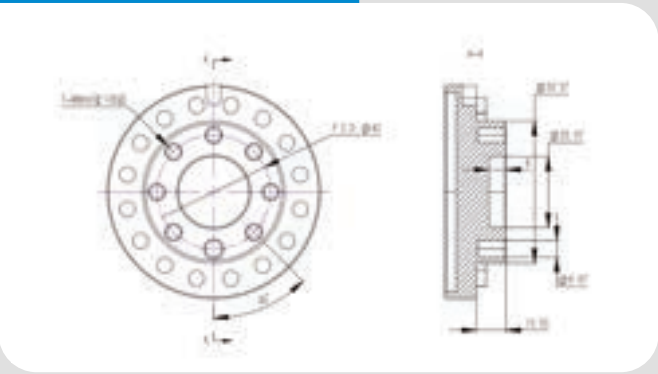

PRODUCT PARAMETERS

No. Control Axes		6
Max Load Capacity		25
Max. Reach (mm)		1813
Pos.rep(mm)		±0.05
Motion Range (°)	J1 Axis	±180
	J2 Axis	+156/-99
	J3 Axis	+75/-200
	J4 Axis	±180
	J5 Axis	±135
	J6 Axis	±360
Max. Speed* (° /s)	J1 Axis	204
	J2 Axis	186
	J3 Axis	182
	J4 Axis	492
	J5 Axis	450
	J6 Axis	705

Motor Output (kw)	J1 Axis	3
	J2 Axis	3
	J3 Axis	1.5
	J4 Axis	0.4
	J5 Axis	0.4
	J6 Axis	0.4
Weight (kg)		≈256
Installation		Floor, Upside-down, Angle
Levels of protection		IP56(wrist:IP67)
Ambient temperature / Humidity / Vibration		Ambient temperature: 0~45°C Ambient humidity: Normally 20-80%RH or less (No dew, nor frost allow) Short term 90 %RH or less (within one month) Vibration acceleration: 4.9 m/s (0.5G) or less
Electronic Control Box Specification	Power Supply	Three-phase 380VAC 50Hz/60Hz
	Size	522mm x 408mm x 425mm

R Series 35KG

LA1813-35



PRODUCT FEATURES

- High-speed and high-precision with $\pm 0.05\text{mm}$ position repeatability
- Equipped with 16/24 I/O and is easily expandable for more complex applications
- Standard IP65 (wrist IP67) proved long term operation in harsh environment
- Equipped with 2 quick pneumatic connections and 24 I/O bus connections
- Provides 1~3 pneumatic valves suitable for grippers in handling and loading/unloading applications
- Provide 3 mounting methods: Floor, Upside-down, and Angle mount

MAIN APPLICATIONS

Loading/unloading

Handling

Grinding

Assembling

Palletizing

Others

Robot Work Envelope

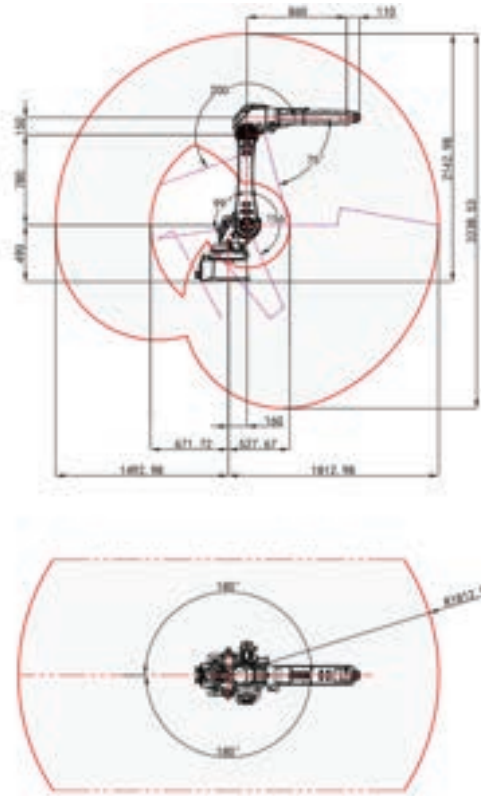

Robot Base Dimension

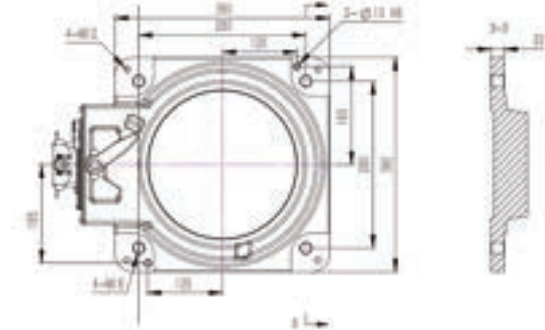

Robot Flange Dimension

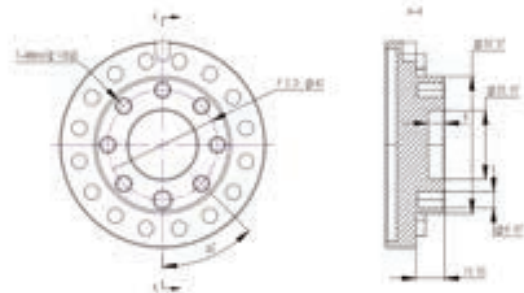

R
C
K
H
Y
Series

PRODUCT PARAMETERS

No. Control Axes		6
Max Load Capacity		35
Max. Reach (mm)		1813
Pos.rep(mm)		±0.05
Motion Range (°)	J1 Axis	±180
	J2 Axis	+156/-99
	J3 Axis	+75/-200
	J4 Axis	±180
	J5 Axis	±135
	J6 Axis	±360
Max. Speed* (° /s)	J1 Axis	204
	J2 Axis	186
	J3 Axis	182
	J4 Axis	310
	J5 Axis	360
	J6 Axis	444

Motor Output (kw)	J1 Axis	3
	J2 Axis	3
	J3 Axis	1.5
	J4 Axis	0.4
	J5 Axis	0.4
	J6 Axis	0.4
Weight (kg)		≈256
Installation		Floor, Upside-down, Angle
Levels of protection		IP56(wrist:IP67)
Ambient temperature / Humidity / Vibration		Ambient temperature: 0~45°C Ambient humidity: Normally 20-80%RH or less (No dew, nor frost allow) Short term 90 %RH or less (within one month) Vibration acceleration: 4.9 m/s (0.5G) or less
Electronic Control Box Specification	Power Supply	Three-phase 380VAC 50Hz/60Hz
	Size	522mm x 408mm x 425mm

C Series 10KG

LA1468-10



PRODUCT CHARACTERISTICS

- Suitable for light and medium payload operations in wide range of applications
- Equipped with 16/24 I/O, 2 DA and 1 AD interface is easily expandable for more complex applications
- Equipped 12 I/O bus connections and 10mm air tube inside for easier cable management
- Provide 3 mounting methods: Floor, Upside-down and Angle mount

MAIN APPLICATIONS

Loading/unloading

Welding

Others

Assembling

Robot Work Envelope

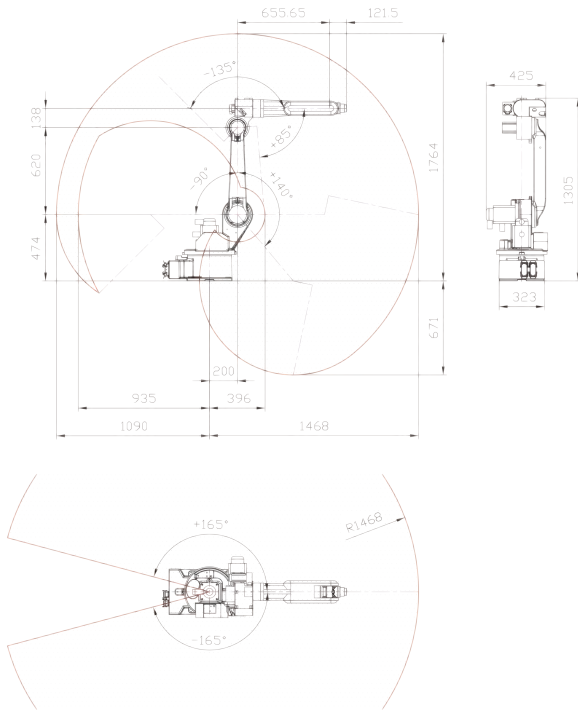

Robot Base Dimension

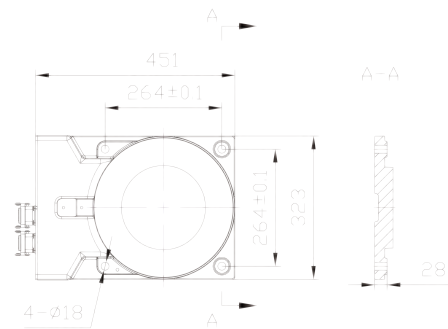

Robot Flange Dimension

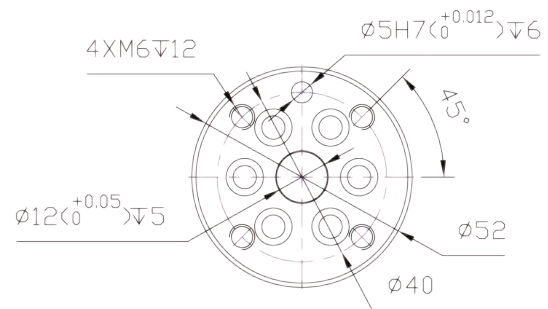

PRODUCT PARAMETERS

No. Control Axes	6	
Max Load Capacity	10	
Max. Reach (mm)	1468	
Pos.rep(mm)	±0.05	
Motion Range (°)	J1 Axis	±165
	J2 Axis	+140/-90
	J3 Axis	+85/-135
	J4 Axis	±180
	J5 Axis	±129
	J6 Axis	±360
Max. Speed* (°/s)	J1 Axis	200
	J2 Axis	134
	J3 Axis	268
	J4 Axis	260
	J5 Axis	250
	J6 Axis	443

Motor Output (kw)	J1 Axis	1.5
	J2 Axis	1.5
	J3 Axis	0.75
	J4 Axis	0.2
	J5 Axis	0.2
	J6 Axis	0.2
Weight (kg)	≈158	
Installation	Floor, Upside-down, Angle	
Levels of protection	IP54	
Ambient temperature / Humidity / Vibration	Ambient temperature: 0~45°C Ambient humidity: Normally 75 %RH or less (No dew, nor frost allow) Short term 90 %RH or less (within one month) Vibration acceleration: 4.9 m/s (0.5G) or less	
Electronic Control Box Specification	Power Supply	Single Phase 200-230VAC, 50Hz/60Hz
	Size	580mm x 460mm x 870mm

C Series 20KG

LA1717-20



PRODUCT CHARACTERISTICS

- Suitable for light and medium payload operations in wide range of applications
- Equipped with 16/24 I/O, 2 DA and 1 AD interface is easily expandable for more complex applications
- Equipped 12 I/O bus connections and 10mm air tube inside for easier cable management
- Provide 3 mounting methods: Floor, Upside-down and Angle mount

MAIN APPLICATIONS

Loading/unloading

Welding

Others

Assembling

Robot Work Envelope

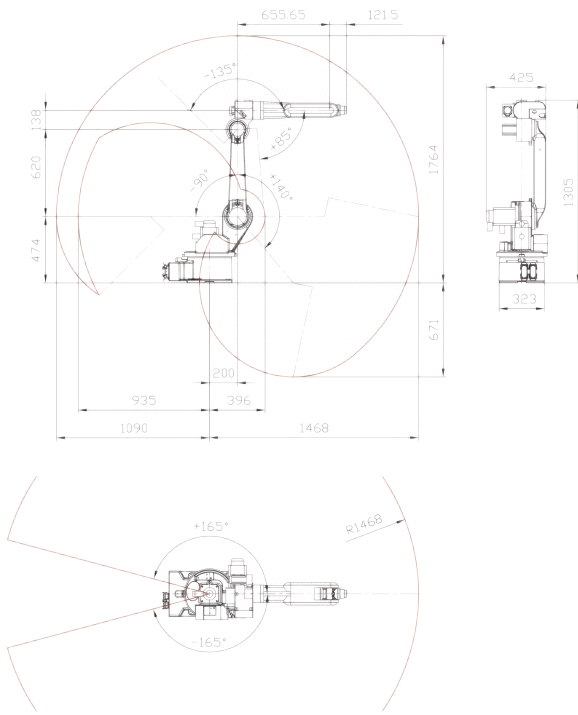

Robot Base Dimension

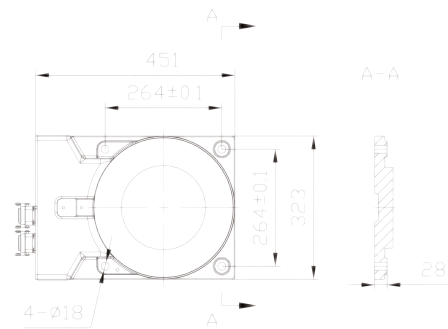

Robot Flange Dimension

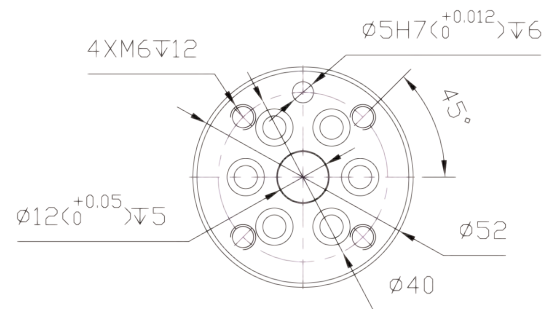

PRODUCT PARAMETERS

No. Control Axes	6	
Max Load Capacity	20	
Max. Reach (mm)	1717	
Pos.rep(mm)	±0.05	
Motion Range (°)	J1 Axis	±160
	J2 Axis	+150/-100
	J3 Axis	+85/-160
	J4 Axis	±180
	J5 Axis	±130
	J6 Axis	±360
Max. Speed* (°/s)	J1 Axis	147
	J2 Axis	101
	J3 Axis	134
	J4 Axis	200
	J5 Axis	321
	J6 Axis	319

Motor Output (kw)	J1 Axis	1.5
	J2 Axis	2
	J3 Axis	1.5
	J4 Axis	0.4
	J5 Axis	0.2
	J6 Axis	0.2
Weight (kg)	≈270	
Installation	Floor, Upside-down, Angle	
Levels of protection	IP54	
Ambient temperature / Humidity / Vibration	Ambient temperature: 0~45°C Ambient humidity: Normally 75 %RH or less (No dew, nor frost allow) Short term 90 %RH or less (within one month) Vibration acceleration: 4.9 m/s (0.5G) or less	
Electronic Control Box Specification	Power Supply	Single Phase 200-230VAC, 50Hz/60Hz
	Size	580mm x 460mm x 870mm

C Series 8KG

LA2000-8 Long arm type



PRODUCT CHARACTERISTICS

- Suitable for welding and loading/unloading light payload with extended reach design
- Equipped with 16/24 I/O, 2 DA and 1 AD interface is easily expandable for more complex applications
- Equipped 12 I/O bus connections and 10mm air tube inside for easy cable management
- Provide 3 mounting methods: Floor, Upside-down, and Angle mount

MAIN APPLICATIONS

Loading/unloading

Handling

Welding

Assembling

Others

Robot Work Envelope

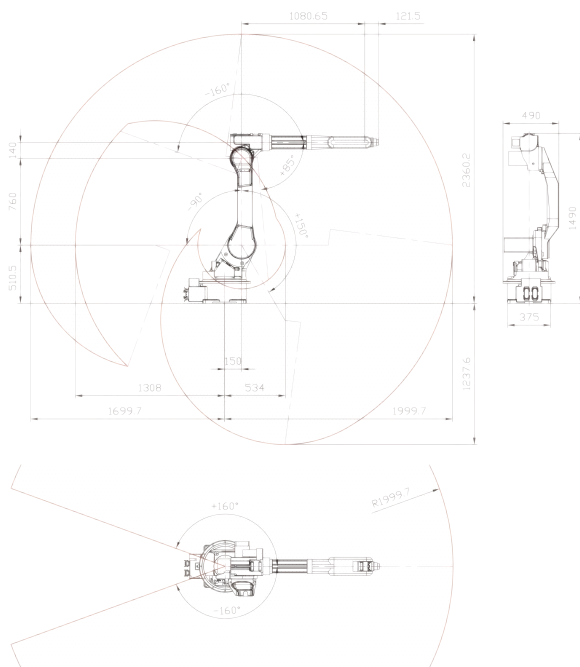

Robot Base Dimension

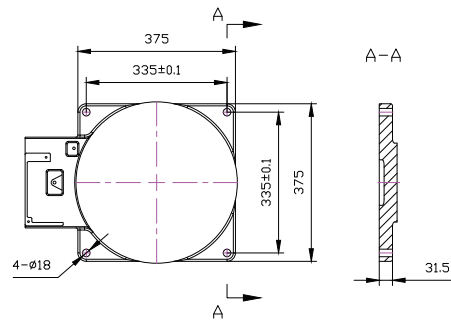

Robot Flange Dimension

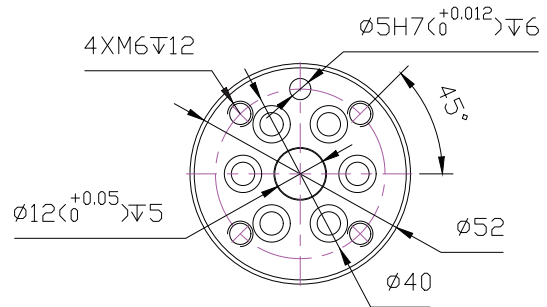

PRODUCT PARAMETERS

No. Control Axes		6
Max Load Capacity		8
Max. Reach (mm)		2000
Pos.rep(mm)		±0.05
Motion Range (°)	J1 Axis	±160
	J2 Axis	+150/-90
	J3 Axis	+85/-160
	J4 Axis	±180
	J5 Axis	±129
	J6 Axis	±360
Max. Speed* (°/s)	J1 Axis	147
	J2 Axis	101
	J3 Axis	134
	J4 Axis	200
	J5 Axis	250
	J6 Axis	443

Motor Output (kw)	J1 Axis	1.5
	J2 Axis	2
	J3 Axis	1.5
	J4 Axis	0.4
	J5 Axis	0.2
	J6 Axis	0.2
Weight (kg)		≈270
Installation		Floor, Upside-down, Angle
Levels of protection		IP54
Ambient temperature / Humidity / Vibration		Ambient temperature: 0~45°C Ambient humidity: Normally 75 %RH or less (No dew. nor frost allow) Short term 90 %RH or less (within one month) Vibration acceleration: 4.9 m/s (0.5G) or less
Electronic Control Box Specification	Power Supply	Single Phase, 200-230VAC, 50Hz/60Hz
	Size	580mm × 460mm × 870mm

C Series 60KG

LA2100-60



PRODUCT CHARACTERISTICS

- Suitable for heavy payload, large workpiece with wide range of arm span
- Equipped with 16 I interfaces, 24 O interfaces, 2 DA and 1 AD interface , support quick expansion of IO board

MAIN APPLICATIONS

Loading/unloading

Handling

Grinding

Assembling

Others

K Series 13KG

LA1460-13



PRODUCT CHARACTERISTICS

- High-speed and high-precision with $\pm 0.03\text{mm}$ position repeatability
- Compact machine and large arm range provide multiple installation methods
- Equipped with 16/24 I/O, 2 DA and 1 AD interface is easily expandable for more complex applications
- High IP rating of IP67 protection

MAIN APPLICATIONS

Loading/unloading

Handling

Grinding

Assembling

Others

Robot Work Envelope

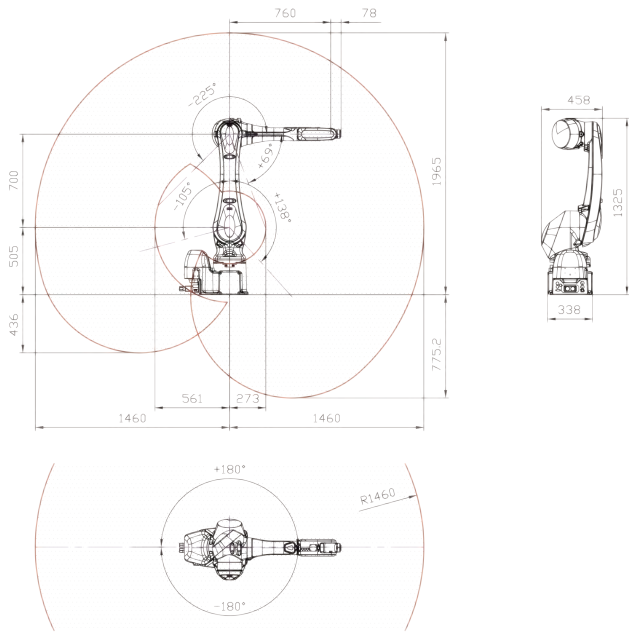

Robot Base Dimension

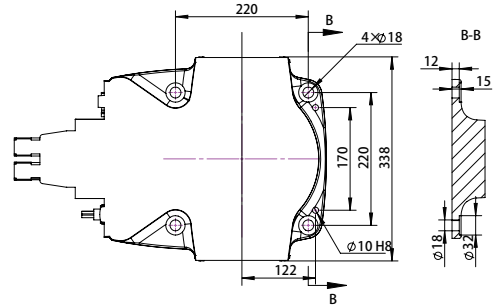

Robot Flange Dimension

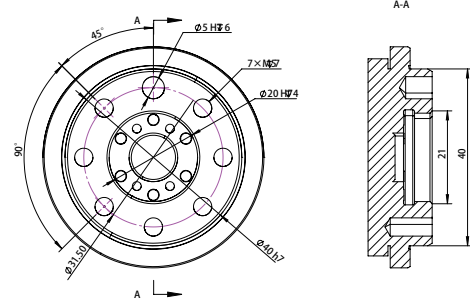

PRODUCT PARAMETERS

No. Control Axes	6	
Max Load Capacity	13	
Max. Reach (mm)	1460	
Pos.rep(mm)	±0.03	
Motion Range (°)	J1 Axis	±180
	J2 Axis	+138/-105
	J3 Axis	+69/-225
	J4 Axis	±200
	J5 Axis	+125
	J6 Axis	±360
Max. Speed* (°/s)	J1 Axis	265
	J2 Axis	250
	J3 Axis	265
	J4 Axis	475
	J5 Axis	475
	J6 Axis	730

Motor Output (kw)	J1 Axis	1.5
	J2 Axis	1.5
	J3 Axis	0.75
	J4 Axis	0.2
	J5 Axis	0.2
	J6 Axis	0.2
Weight (kg)	≈ 170	
Installation	Floor, upside-down	
Levels of protection	IP67	
Ambient temperature / Humidity / Vibration	Ambient temperature: 0~45°C Ambient humidity: Normally 75 %RH or less (No dew, nor frost allow) Short term 90 %RH or less (within one month) Vibration acceleration: 4.9 m/s (0.5G) or less	
Electronic Control Box Specification	Power Supply	Single Phase 200-230VAC 50Hz/60Hz
	Size	580mm x 460mm x 870mm

K Series 20KG

LA1725-20



PRODUCT CHARACTERISTICS

- High-speed and high-precision with $\pm 0.04\text{mm}$ position repeatability
- Compact machine and large arm range provide multiple installation methods
- Equipped with 16/24 I/O, 2 DA and 1 AD interface is easily expandable for more complex applications
- Basement IP65 protection with wrist to IP67 high protection

MAIN APPLICATIONS

Loading/unloading

Handling

Grinding

Assembling

Others

Robot Work Envelope

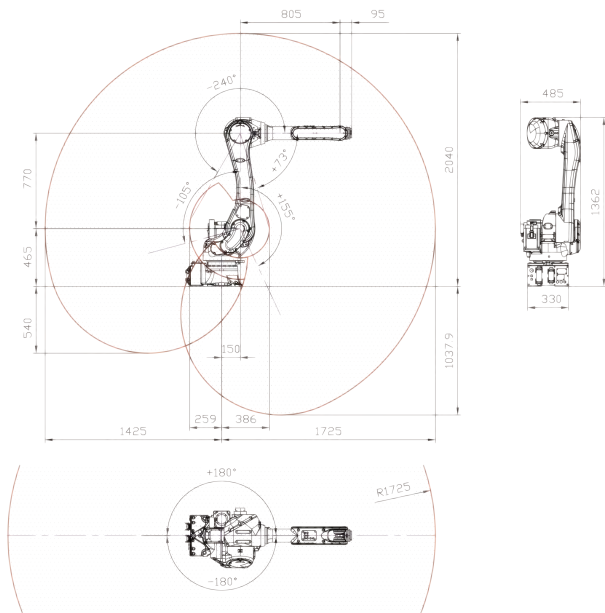

Robot Base Dimension

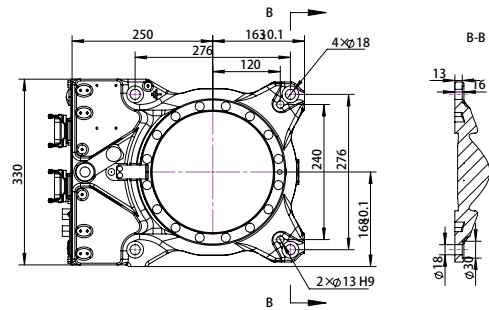

Robot Flange Dimension

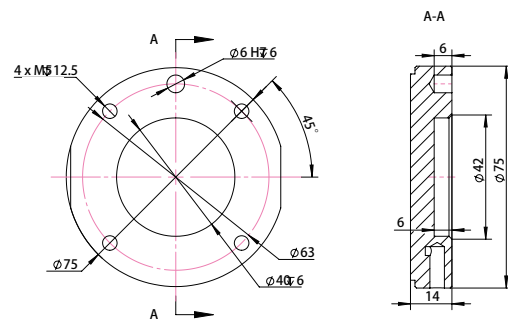

PRODUCT PARAMETERS

No. Control Axes		6
Max Load Capacity		20
Max. Reach (mm)		1725
Pos.rep(mm)		±0.04
Motion Range (°)	J1 Axis	±180
	J2 Axis	+155/-105
	J3 Axis	+73/-240
	J4 Axis	±270
	J5 Axis	+145
	J6 Axis	±360
Max. Speed* (°/s)	J1 Axis	190
	J2 Axis	205
	J3 Axis	210
	J4 Axis	400
	J5 Axis	360
	J6 Axis	610

Motor Output (kw)	J1 Axis	2
	J2 Axis	2
	J3 Axis	0.675
	J4 Axis	0.2
	J5 Axis	0.2
	J6 Axis	0.2
Weight (kg)		≈230
Installation		Floor, Upside-down
Levels of protection		Wrist part : IP67 Base part : IP65
Ambient temperature / Humidity / Vibration		Ambient temperature: 0~45°C Ambient humidity: Normally 75 %RH or less (No dew, nor frost allow) Short term 90 %RH or less (within one month) Vibration acceleration: 4.9 m/s (0.5G) or less
Electronic Control Box Specification	Power Supply	Single Phase 200-230VAC, 50Hz/60Hz
	Size	580mm x 460mm x 870mm

H Series Collaborative 5KG

LC800-5



PRODUCT CHARACTERISTICS

- Compliant with ISO 15066 collaborative safety standards
- Compact and lightweight for easy transportation and assembling
- Supports hand guiding function for enhanced intuitive teaching
- Supports collision protection for human-machine collaboration safety without safety fence
- Equipped with 16/16 I/O, 2 DA, 2 AD, and safety inputs signal
- Standard IP66 proved long term operation in harsh environment
- Provide 3 mounting methods: Floor, Upside-down, and Angle mount

MAIN APPLICATIONS

Loading/unloading

Handling

Assembling

Others

Robot Work Envelope

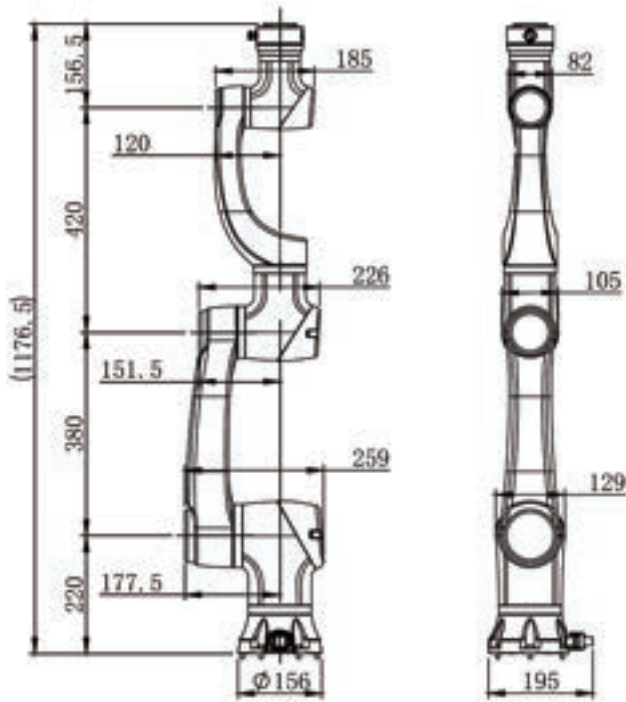

Robot Base Dimension

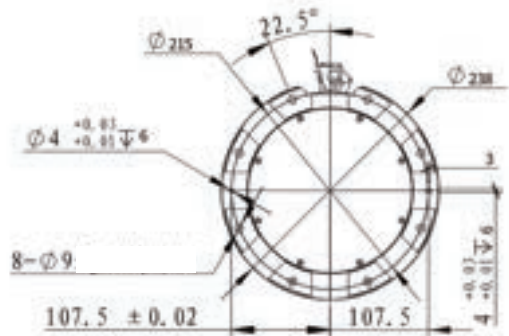

Robot Flange Dimension

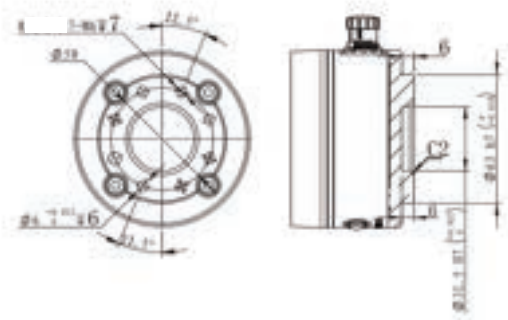

PRODUCT PARAMETERS

No. Control Axes		6
Max Load Capacity		5
Max. Reach (mm)		800
Pos.rep(mm)		±0.02
Motion Range (°) <small>While the joints have a ±360° capability, this may be limited by the application scenario, and each joint may not reach this capability. Please be mindful of this during actual use.</small>	J1 Axis	±360
	J2 Axis	±360
	J3 Axis	±360
	J4 Axis	±360
	J5 Axis	±360
	J6 Axis	±360
Max. Speed* (°/s)	J1 Axis	180
	J2 Axis	180
	J3 Axis	180
	J4 Axis	180
	J5 Axis	200
	J6 Axis	200

Weight (kg)		≈ 25
Installation		Floor, Upside-down, Angle
Levels of protection		IP66
Ambient temperature / Humidity / Vibration		Ambient temperature: 0-50°C Ambient humidity: Normally 75 %RH or less (No dew, nor frost allow) Short term 90 %RH or less (within one month) Vibration acceleration: 4.9 m/s (0.5G) or less
Electronic Control Box Specification	Power Supply	Single Phase 200-230VAC, 50Hz/60Hz
	Size	445.2mm x 318.8mm x 536mm

H Series Collaborative 10KG

LC1000-10



PRODUCT CHARACTERISTICS

- Compliant with ISO 15066 collaborative safety standards
- Compact and lightweighted for easy transportation and assembling
- Supports hand guiding function for enhanced intuitive teaching
- Supports collision protection for human-machine collaboration safety without safety fence
- Equipped with 16/16 I/O, 2 DA, 2 AD, and safety inputs signal
- Standard IP66 proved long term operation in harsh environment
- Provide 3 mounting methods: Floor, Upside-down, and Angle mount

MAIN APPLICATIONS

Loading/unloading

Handling

Assembling

Others

Robot Work Envelope

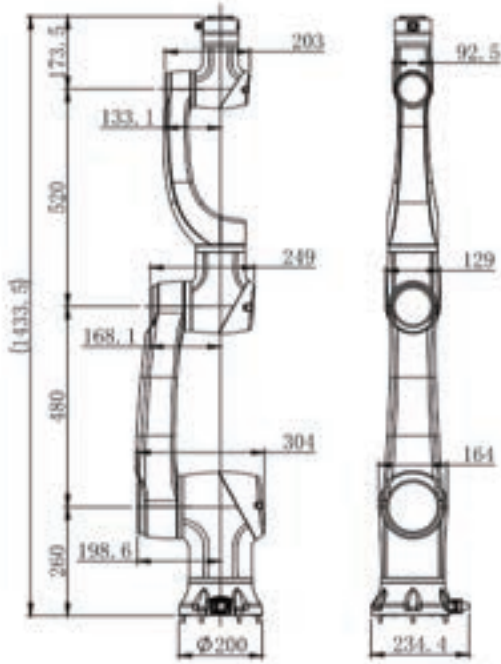

Robot Base Dimension

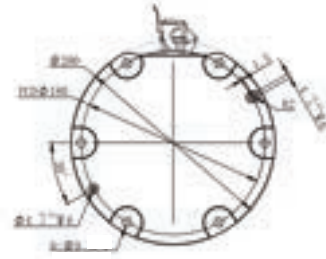

Robot Flange Dimension

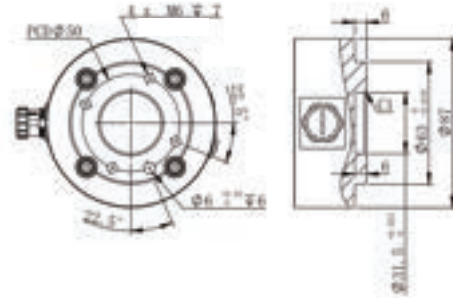

PRODUCT PARAMETERS

No. Control Axes		6
Max Load Capacity		10
Max. Reach (mm)		1000
Pos.rep(mm)		±0.03
Motion Range (°)	J1 Axis	±360
	J2 Axis	±360
	J3 Axis	±360
	J4 Axis	±360
	J5 Axis	±360
	J6 Axis	±360
Max. Speed* (°/s)	J1 Axis	100
	J2 Axis	100
	J3 Axis	150
	J4 Axis	150
	J5 Axis	180
	J6 Axis	180

While the joints have a ±360° capability, this may be limited by the application scenario, and each joint may not reach this capability. Please be mindful of this during actual use.

Weight (kg)		≈43
Installation		Floor, Upside-down, Angle
Levels of protection		IP66
Ambient temperature / Humidity / Vibration		Ambient temperature: 0~50°C Ambient humidity: Normally 75 %RH or less (No dew, nor frost allow) Short term 90 %RH or less (within one month) Vibration acceleration: 4.9 m/s (0.5G) or less
Electronic Control Box Specification	Power Supply	Single Phase 200-230VAC, 50Hz/60Hz
	Size	445.2mm x 318.8mm x 536mm

H Series Collaborative 15KG

LC1300-15



PRODUCT CHARACTERISTICS

- Compliant with ISO 15066 collaborative safety standards
- Compact and lightweighted for easy transportation and assembling
- Supports hand guiding function for enhanced intuitive teaching
- Supports collision protection for human-machine collaboration safety without safety fence
- Equipped with 16/16 I/O, 2 DA, 2 AD, and safety inputs signal
- Standard IP66 proved long term operation in harsh environment
- Provide 3 mounting methods: Floor, Upside-down, and Angle mount

MAIN APPLICATIONS

Loading/unloading

Handling

Assembling

Others

Robot Work Envelope

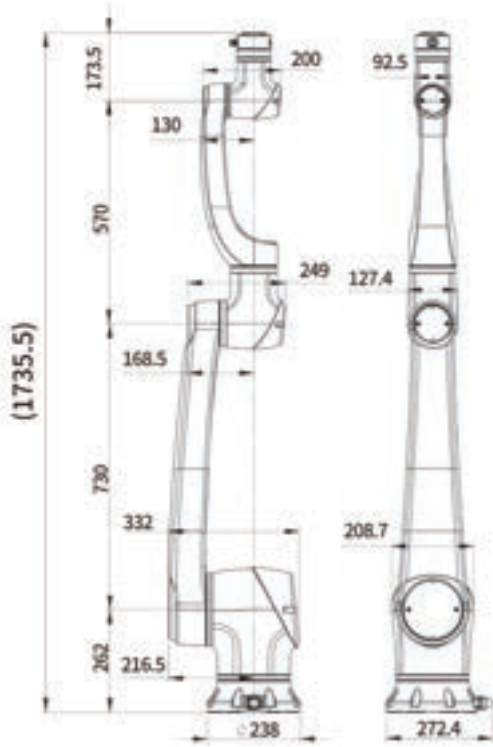

Robot Base Dimension

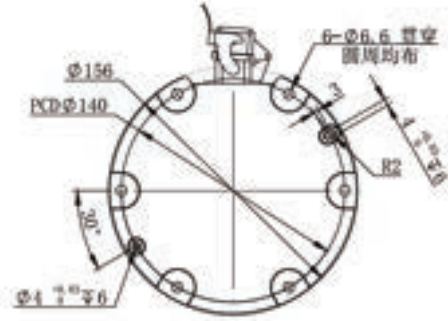

Robot Flange Dimension

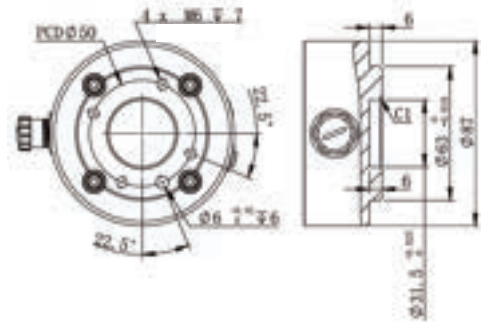

PRODUCT PARAMETERS

No. Control Axes		6
Max Load Capacity		15
Max. Reach (mm)		1300
Pos.rep(mm)		± 0.05
Motion Range (°)	J1 Axis	± 360
	J2 Axis	± 360
	J3 Axis	± 360
	J4 Axis	± 360
	J5 Axis	± 360
	J6 Axis	± 360
Max. Speed* (°/s)	J1 Axis	80
	J2 Axis	80
	J3 Axis	120
	J4 Axis	120
	J5 Axis	150
	J6 Axis	150

While the joints have a $\pm 360^\circ$ capability, this may be limited by the application scenario, and each joint may not reach this capability. Please be mindful of this during actual use.

Weight (kg)		≈ 60
Installation		Floor, Upside-down, Angle
Levels of protection		IP66
Ambient temperature / Humidity / Vibration		Ambient temperature: 0-50°C Ambient humidity: Normally 75%RH or less (No dew, nor frost allow) Short term 90%RH or less (within one month) Vibration acceleration: 4.9 m/s (0.5G) or less
Electronic Control Box Specification	Power Supply	Single Phase 200-230VAC, 50Hz/60Hz
	Size	445.2mm x 318.8mm x 536mm

R

C

K

H

Y

Series

Y Series 4-axis 3KG

LS400-3



PRODUCT FEATURES

- High-speed and high-precision with ± 0.01 mm position repeatability
- Compact and lightweight: Suitable for light and small loads and applications with limited movement space.
- Equipped with 16I/16O and is easily expandable for more complex applications
- Equipped 8 I/O bus connections and 2 pneumatic connections inside for easy cable management

MAIN APPLICATIONS

Handling

Assembling

Palletizing

Others

Robot Work Envelop

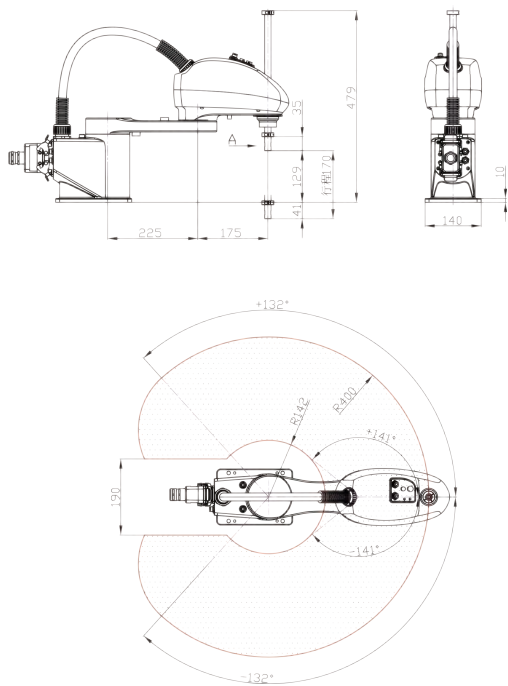

Robot Base Dimension

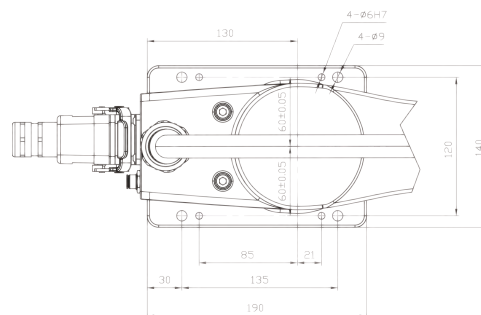

Robot Flange Dimension

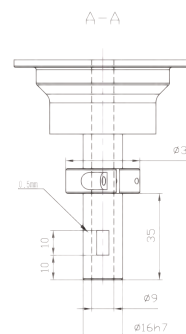

PRODUCT PARAMETERS

No. Control Axes		4	
Max Load Capacity		3	
Max. Reach (mm)		400	
Pos.rep	J1Axis/ J2Axis	(mm)	±0.01
	J3 Axis	(mm)	±0.01
	J4 Axis	(°)	±0.01
Motion Range (°)	J1 Axis	(°)	±132
	J2 Axis	(°)	±141
	J3 Axis	(mm)	0/-170
	J4 Axis	(°)	±360
Max. Speed* (°/s)	J1 Axis	(°/s)	720
	J2 Axis	(°/s)	720
	J3 Axis	(mm/s)	1100
	J4 Axis	(°/s)	2500

Motor Output (kw)	J1 Axis	0.4
	J2 Axis	0.1
	J3 Axis	0.1
	J4 Axis	0.1
Weight (kg)	≈13	
Installation	Floor	
Levels of protection	IP20	
Ambient temperature / Humidity / Vibration	Ambient temperature:0~45°C Ambient humidity:Normally 75 %RH or less (No dew. nor frost allow) Short term 90 %RH or less (within one month) Vibration acceleration: 4.9 m/s (0.5G) or less	
Electronic Control Box Specification	Power Supply	Single Phase 200-230VAC, 50Hz/60Hz
	Size	380mm x 510mm x 305mm

Y Series 4-axis 6KG

LS600-6



PRODUCT FEATURES

- High-speed and high-precision with $\pm 0.02\text{mm}$ position repeatability
- Compact and lightweight: Suitable for light and small loads and applications with limited movement space.
- Equipped with 16/16 I/O and is easily expandable for more complex applications
- Equipped 8 I/O bus connections and 2 pneumatic connections inside for easy cable management
- Standard option with IP54 high protection performance, suitable for complex working environment

MAIN APPLICATIONS

Handling

Assembling

Palletizing

Others

Robot Work Envelop

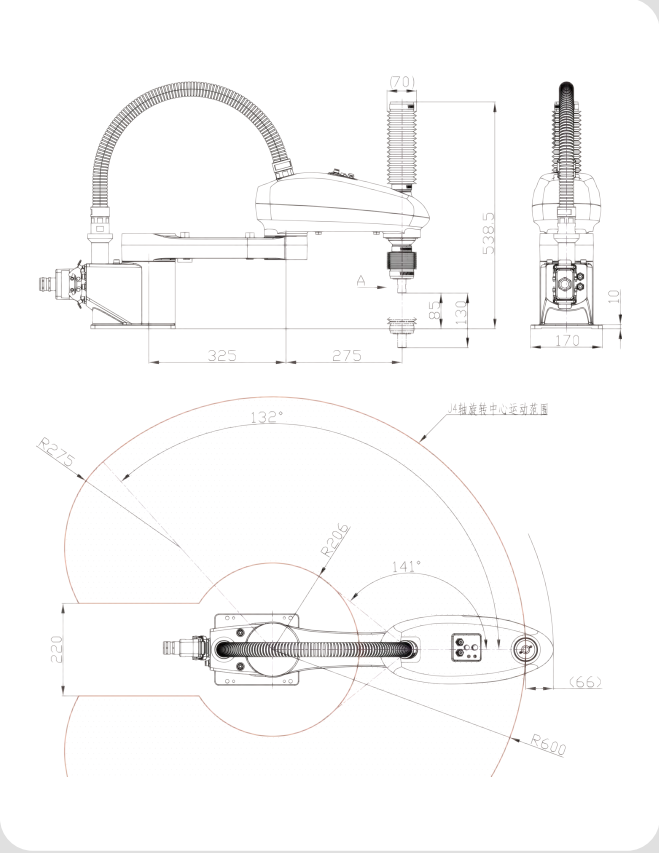

Robot Base Dimension

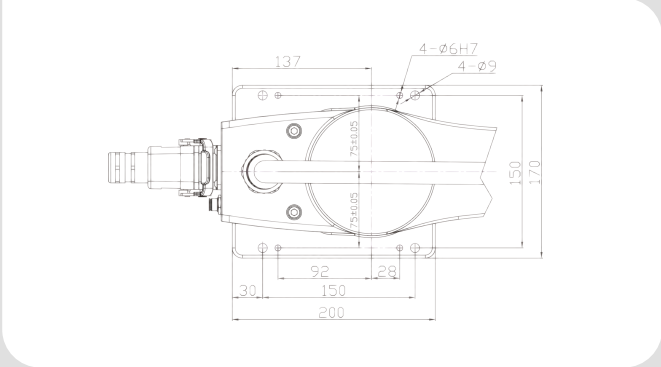

Robot Flange Dimension

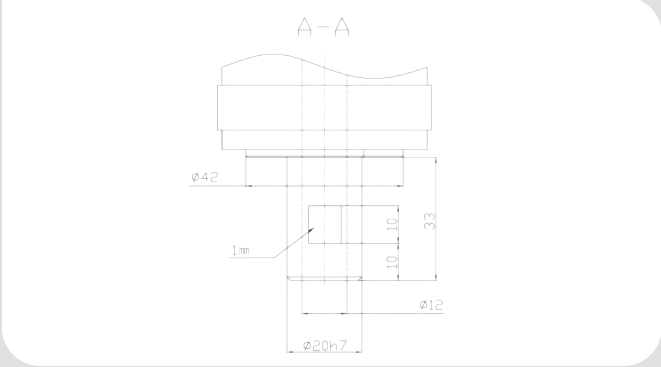

PRODUCT PARAMETERS

No. Control Axes		4	
Max Load Capacity		6	
Max. Reach (mm)		600	
Pos.rep	J1Axis/ J2Axis	(mm)	±0.02
	J3 Axis	(mm)	±0.01
	J4 Axis	(°)	±0.01
Motion Range (°)	J1 Axis	(°)	±132
	J2 Axis	(°)	±141
	J3 Axis	(mm)	0/-130
	J4 Axis	(°)	±360
Max. Speed* (°/s)	J1 Axis	(°/s)	450
	J2 Axis	(°/s)	720
	J3 Axis	(mm/s)	1100
	J4 Axis	(°/s)	2000

Motor Output (kw)	J1 Axis	0.4
	J2 Axis	0.2
	J3 Axis	0.1
	J4 Axis	0.1
Weight (kg)	≈ 17	
Installation	Floor	
Levels of protection	IP54	
Ambient temperature / Humidity / Vibration	Ambient temperature: 0-45°C Ambient humidity: Normally 75 %RH or less (No dew, nor frost allow) Short term 90 %RH or less (within one month) Vibration acceleration: 4.9 m/s (0.5G) or less	
Electronic Control Box Specification	Power Supply	Single Phase 200-230VAC, 50Hz/60Hz
	Size	380mm x 510mm x 305mm

Y Series 4-axis 10KG

LS900-10



PRODUCT FEATURES

- High-speed and high-precision with $\pm 0.02\text{mm}$ position repeatability
- Compact and lightweight: Suitable for light and small loads and applications with limited movement space.
- Equipped with 16/16 I/O and is easily expandable for more complex applications
- Equipped 8 I/O bus connections and 2 pneumatic connections inside for easier cable management

MAIN APPLICATIONS

Handling

Assembling

Palletizing

Others

Robot Work Envelop

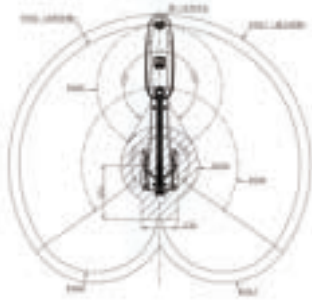
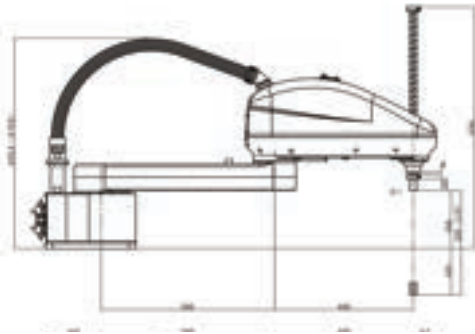

Robot Base Dimension

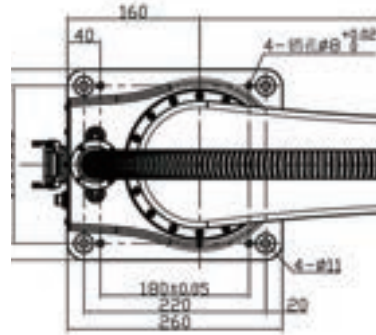

Robot Flange Dimension

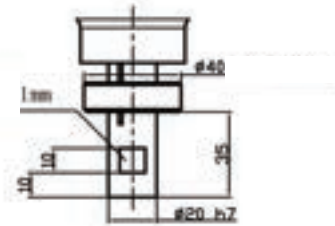

PRODUCT PARAMETERS

No. Control Axes			4
Max Load Capacity			10
Max. Reach (mm)			900
Pos.rep	J1Axis/ J2Axis	(mm)	±0.02
	J3 Axis	(mm)	±0.01
	J4 Axis	(°)	±0.01
Motion Range (°)	J1 Axis	(°)	±125
	J2 Axis	(°)	±150
	J3 Axis	(mm)	0/-300
	J4 Axis	(°)	±360
Max. Speed* (°/s)	J1 Axis	(°/s)	300
	J2 Axis	(°/s)	375
	J3 Axis	(mm/s)	1041
	J4 Axis	(°/s)	1500

Motor Output (kw)	J1 Axis	0.75
	J2 Axis	0.4
	J3 Axis	0.2
	J4 Axis	0.2
Weight (kg)		≈41
Installation		Floor
Levels of protection		IP20
Ambient temperature / Humidity / Vibration		Ambient temperature: 0~45°C Ambient humidity: Normally 75 %RH or less (No dew, nor frost allow) Short term 90 %RH or less (within one month) Vibration acceleration: 4.9 m/s (0.5G) or less
Electronic Control Box Specification	Power Supply	Single Phase 200-230VAC, 50Hz/60Hz
	Size	380mm x 510mm x 305mm

Flexible Robot Cell Products

Double-layer trolley robot

LXC100-906R

LXC100-1206R

LXC11P-1468C

LXC11P-1717C



Rotation trolley robot

LXC200-1206R



PRODUCT CHARACTERISTICS

- Enable rapid deployment by flexible mobile design with lockable casters and fixed brackets
- Equipped with double-layer/rotation trolley control buttons and safety fence, ensuring safety during production
- Achieve robot-to-machine communication with just one Ethernet cable or IO connector
- Simply test communication signals and teach pick-and-place positions to save on-site setup time
- Swiftly reposition or change processing products according to production plans, meeting line change requirements seamlessly
- Add new workpieces for processing without stopping the machine, enabling uninterrupted production cycles
- Compatible with an optional rotary table, LEANTEC product facilitates automatic flipping of workpieces for dual-end processing

MAIN APPLICATIONS

Milling machine

Machine center

Lathe

Tapping machine

Others

Double-layer trolley robot

PRODUCT PARAMETERS

Product type	LXC100-906R	LXC11P-1468C	LXC100-1206R	LXC11P-1717C
Coordinate robot type	LA906-6	LA1468-10	LA1206-10	LA1717-20
Payload(kg)	6	10	10	20
Reach(mm)	906	1468	1206	1717
Pos.rep(mm)	±0.03	±0.05	±0.05	±0.05
Protection	IP67	IP54	IP54	IP54
Product size(mm)	1700×760	2400×850	1700×760	2400×850
Material tray size(mm)	570×420	800×600	570×420	800×600
Material tray maximum load(kg)	60	80	60	80
Suitable workpiece type	Medium/small type, angle location demand	Medium/small type, angle location demand	Medium/small type, angle location demand	Medium/big type, angle location demand
Suitable workpiece height(mm)	90	135	90	135
End effector	Optional	Optional	Optional	Optional

Rotation trolley robot

PRODUCT PARAMETERS

Product type	LXC200-1206R
Coordinate robot type	LA1206-10
Robot maximum load(kg)	10
Robot working radius(mm)	1206
Repeat location precision(mm)	±0.05
Robot protection level	IP54
Product size(mm)	1950 X 800
Matching workpiece size(mm)	Outer circle 25-160
Material storehouse station amount	8
Material storehouse single station load(kg)	50
Single station height(mm)	410
Material station transmission	Chain transmission
End effector	Optional

Cost reduction and efficiency enhancement

Compact modularization design achieves rapid and flexible deployment.



30 minutes
Rapid Deployment

10 minutes
Rapid Changeover



Timing Evaluation 	Deployment	Changeover
LEANTEC flexible robot cell products	30 mins	10 mins
Traditional robot pick and place	>12 hrs	>3 hrs

Optional multiple material storehouse modules could match different workpiece and equipment.

One CNC - one Robot integration smart production



Two CNC - one Robot machines make productivity double

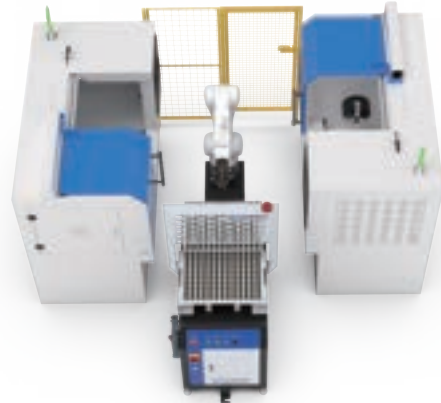

Labor cost comparison

Usual labor production

6 CNC machines,
3 shifts and 9 staffs



labor cost: **about 150,000 USD/per year.**

Implement LEANTEC
flexible robot cell

6 CNC machines,
3 shifts and 3 staffs



labor cost: **about 50,000 USD/per year.**

Activation battle

Common labor production

5 days, 8 hours per day



Implement LEANTEC
Flexible robot cell production

7 days, 24 hours per day



Handling Peripheral Devices

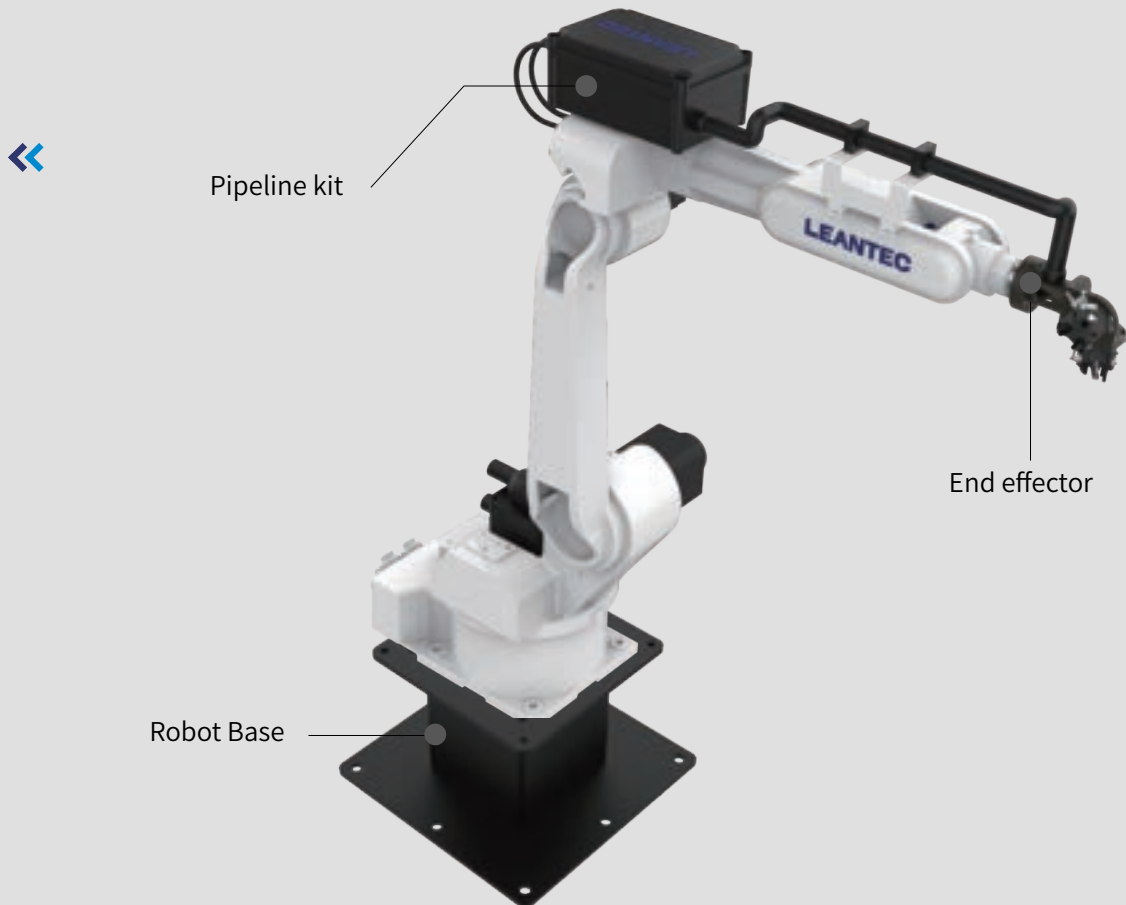

PRODUCT CHARACTERISTICS

- One-stop shop solution tailored for handling and loading/unloading applications
- Includes robot base, pipeline kits and end effectors
- Featuring a modular design, LEANTEC system allows flexible combinations across various specifications
- Options include dual and triple gripper configurations, equipped with a machine chuck chip blowing tube to meet machining tending requirements
- Pre-defined IO interface in both hardware and software ensures plug-and-play capability, significantly reducing implementation costs

MAIN APPLICATIONS

Handling

End Effector



Ready-to-use pneumatic gripper modules compatible with all six-axis robots. It offers options for dual and triple gripper configurations and includes pneumatic tubing for machine chuck chip blowing. Accelerate deployment into production lines with pipeline kits.



Type	Compatible robot	Spec.	Bore size (mm)	Opening/Closing stroke(mm)	Gripping force (N)
MD10-20A-705	All six-axis robots	2 Airtec grippers, 1 blowing tube	32	4	Close 74, Open 82
MD20-20A-705	All six-axis robots	2 Chelic grippers, 1 blowing tube	32	4	Close 62, Open 65
MD26-20C-605	All six-axis robots	2 Chelic grippers, 1 blowing tube	63	8	Close 399, Open 412
MD10-32A-315	All six-axis robots	3 Airtec grippers, 1 blowing tube	32	4	Close 74, Open 82

Pipeline Kit



Ready-to-use pipeline kits, compatible with C-Series 10kg and 20kg six-axis robots. The junction box includes 1-3 sets of solenoid valves for grippers, and 1 for machine chuck chip blowing. Facilitate rapid integration into production lines with the addition of end effectors.



Type	Compatible robot	Spec.	Junction box size(mm)	Valve spec.
GX31-6YC	LA1468-10, LA1717-20	Bellows, Junction box, IO wires, Tubes, Brackets	280*190*130	3 for grippers, 1 for blowing
GX21-6YC	LA1468-10, LA1717-20	Bellows, Junction box, IO wires, Tubes, Brackets	280*190*130	2 for grippers, 1 for blowing
GX11-6YC	LA1468-10, LA1717-20	Bellows, Junction box, IO wires, Tubes, Brackets	280*190*130	1 for grippers, 1 for blowing

Robot Base



Enhance the operating height of 10-20kg six-axis robots to better meet the specific needs of handling, loading/unloading, and other scenarios.

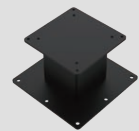

Type	Compatible robot	Product dimensions (mm)	Product weight (kg)	Installation method
DZG-H300-B	LA1468-10, LA1717-20, LA1460-13, LA1725-20	500(Width), 300(Height)	54	Floor
DZG-H500-B	LA1468-10, LA1717-20, LA1460-13, LA1725-20	500(Width), 300(Height)	67	Floor

Rotary Table



Ready-to-use rotary table for loading/unloading applications. In one-to-two or one-to-many machine tending processes, the table automatically rotates workpieces for machining on both ends. It can be seamlessly integrated into production lines and compatible with Robot Cell.



Model	Compatible workpiece	Spec.	Bore size (mm)	Opening/Closing stroke (mm)	Gripping force (N)
FZY-X5B5-GY	Weight <1kg, Height customizable	1 Airtec gripper and rotary valve	50	6	Close 187, Open 204

Welding Robot Products

C Series 6KG

AWA35(P)Q-1600C

AWA50Q-1600C



PRODUCT CHARACTERISTICS

- Light payload with a spacious working area
- Hollow design allows internal routing of welding lines within the arm body, minimizing interference
- Equipped with 16/24 I/O, 2 DA, 1 AD, and is easily expandable for more complex applications
- Provide 3 mounting methods: Floor, Upside-down, and Angle mount
- Compact body design suitable for welding applications

MAIN APPLICATIONS

Welding

Robot Work Envelope

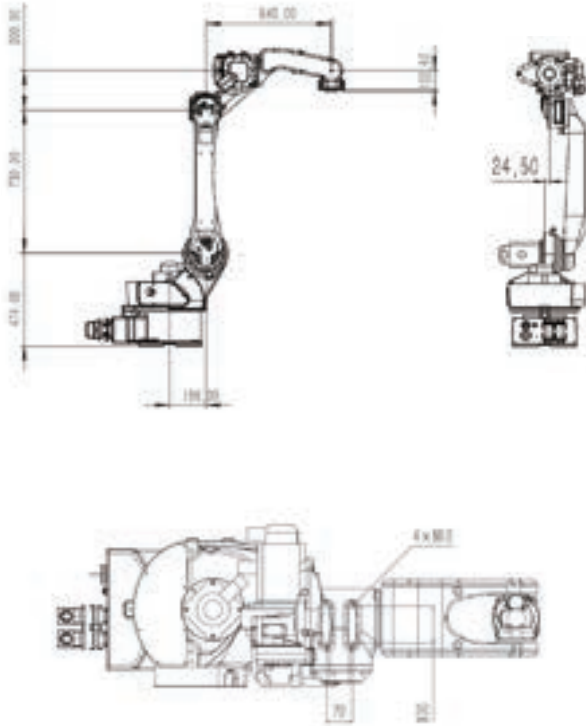

Robot Base Dimension

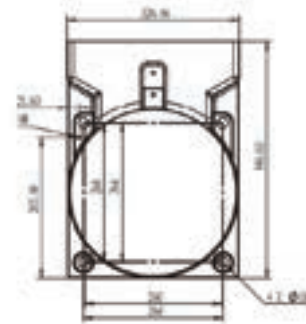

Robot Flange Dimension

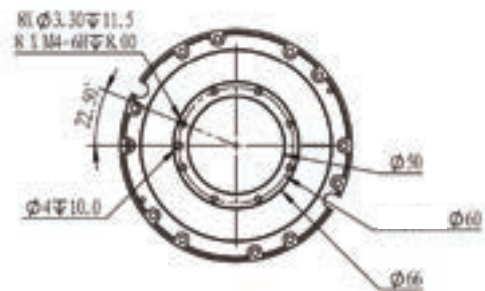

PRODUCT PARAMETERS

No. Control Axes	6	
Max Load Capacity	6	
Max. Reach (mm)	1600	
Pos.rep(mm)	±0.05	
Motion Range (°)	J1 Axis	±170
	J2 Axis	+140/-90
	J3 Axis	+85/-135
	J4 Axis	±180
	J5 Axis	±120
	J6 Axis	±350
Max. Speed* (°/s)	J1 Axis	148
	J2 Axis	148
	J3 Axis	247
	J4 Axis	385
	J5 Axis	444
	J6 Axis	790

Motor Output (kw)	J1 Axis	1.5
	J2 Axis	1.5
	J3 Axis	0.75
	J4 Axis	0.2
	J5 Axis	0.2
	J6 Axis	0.2
Weight (kg)	≈200	
Installation	Floor, Upside-down, Angle	
Levels of protection	IP54	
Ambient temperature / Humidity / Vibration	Ambient temperature: 0~40°C Ambient humidity: Normally 75%RH or less (No dew, nor frost allow) Short term 90 %RH or less (within one month) Vibration acceleration: 4.9 m/s ² (0.5G) or less	
Electronic Control Box Specification	Power Supply	Single Phase 200-230VAC 50Hz/60Hz
	Size	580×460×870mm

Welding Robot Products

C Series 6KG

AWA35(P)Q-2000C Long arm type

AWA50Q-2000C Long arm type



PRODUCT CHARACTERISTICS

- Light payload with a spacious working area
- Hollow design allows internal routing of welding lines within the arm body, minimizing interference
- Equipped with 16/24 I/O, 2 DA, 1 AD, and is easily expandable for more complex applications
- Provide 3 mounting methods: Floor, Upside-down, and Angle mount
- Compact body design suitable for welding applications

MAIN APPLICATIONS

Welding

Robot Work Envelope

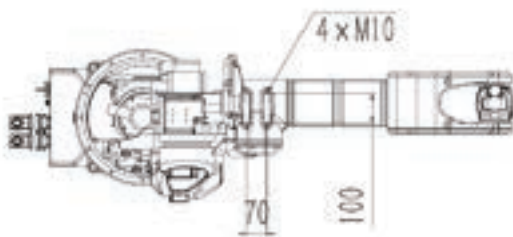
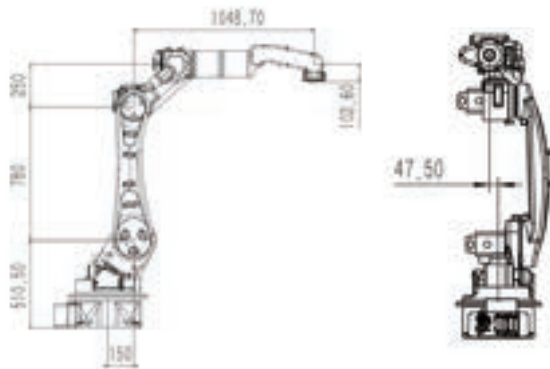

Robot Base Dimension

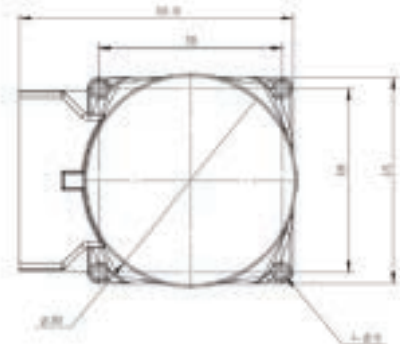

Robot Flange Dimension

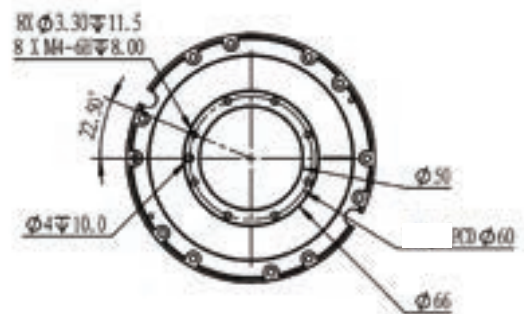

PRODUCT PARAMETERS

No. Control Axes	6	
Max Load Capacity	6	
Max. Reach (mm)	2000	
Pos.rep(mm)	±0.05	
Motion Range (°)	J1 Axis	±170
	J2 Axis	+150/-100
	J3 Axis	+85/-135
	J4 Axis	±180
	J5 Axis	±130
	J6 Axis	±350
Max. Speed* (°/s)	J1 Axis	148
	J2 Axis	148
	J3 Axis	247
	J4 Axis	385
	J5 Axis	444
	J6 Axis	790

Motor Output (kw)	J1 Axis	1.5
	J2 Axis	2
	J3 Axis	1.5
	J4 Axis	0.4
	J5 Axis	0.2
	J6 Axis	0.2
Weight (kg)	≈ 323	
Installation	Floor, Upside-down, Angle	
Levels of protection	IP54	
Ambient temperature / Humidity / Vibration	Ambient temperature: 0~40°C Ambient humidity: Normally 75%RH or less (No dew, nor frost allow) Short term 90 %RH or less (within one month) Vibration acceleration: 4.9 m/s ² (0.5G) or less	
Electronic Control Box Specification	Power Supply	Single Phase 200-230VAC 50Hz/60Hz
	Size	580×460×870mm

Welding Robot Products

Welding Machine



Low Spatter



Stable Wire Feeding



Built-in Database



Digital Control



Save & Restore



User Friendly

PRODUCT PARAMETERS

Product Model	35Q	50Q	35PQ
Rated Input Voltage/Frequency (V/Hz)	3 phase, 380±20%/50	3 phase, 380±20%/50	3 phase, 380±20%/50
Rated Input Capacity (KVA)	14	25	14
Rated Input Current (A)	21	38	28
Rated Output Voltage(V)	31.5	39	31.5
Duty Cycle (%)	60	100	60
OCV (V)	72	73	90
Output Current/Voltage Range (A)	60A/17V~350A/35V	60A/17V~5000A/42V	60A/17V~350A/31.5V
Wire Size (mm)	0.8, 1.0, 1.2, 1.6	0.8, 1.0, 1.2, 1.6	0.8, 1.0, 1.2
Gas Flow (L/Min)	15~20	15~20	15~20
Cooling Method	Air Cooling	Air /Water Cooling	Air Cooling
Protection Class	IP23	IP23	IP23
Insulation Class	H	H	H
Dimension (mm)	660x320x560	660x320x560	660x320x560
Weight (kg)	50	55	60

Robot Applications

Lathe & machining pick and place

CNC Quick Connection Process Package

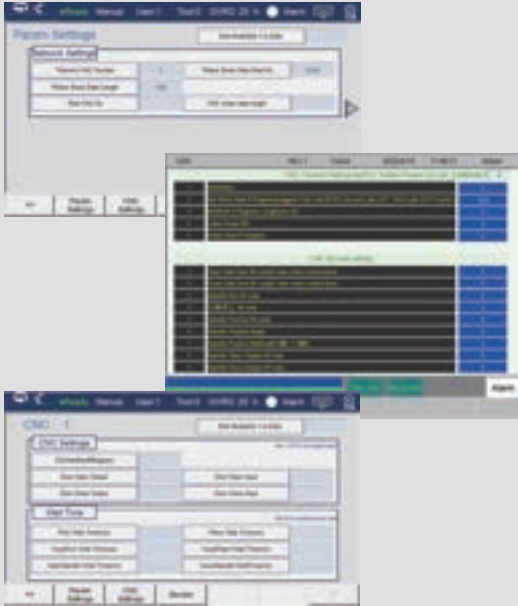

Advantages :

- Fast Communication: Network cable connection with parameter setup allows for quick online connectivity.
- Reduced Wiring: Minimizes the use of physical communication cables, saving costs and simplifying troubleshooting.
- Easy to Learn: Standard software package included, lowering the threshold for adjustment.
- Convenient Maintenance: Standardized processes make teaching easier and maintenance more convenient.



Tool grinder pick and place

Grinder Pick and Place Process Package



Advantages :

- Easy Operation: Calibrate the collet end pick and place position, and change parameters for collet parametric material replacement.
- Smooth Process: Supports multi-segment loading and unloading to prevent material jams.
- Compatible Grippers: Parametric pick and place for pallets, compatible with both single and dual-opening grippers.
- Reduced Recalibration: Teach once during setup; no need for point correction after changing pallets.
- Multi-Scenario Adaptation: Freely set the pick direction and clearance distance to meet various usage scenarios



Robot Applications

Robot Welding

Arc Welding and Laser Welding Process Package



Advantages :

- Complete Software Package: Comprehensive welding instructions, including weaving welding and intermittent welding, to meet various process requirements.
- Fast Tuning:s: Process software support for file saving, facilitating easy process retrieval and transfer.
- Dedicated Process Software : Standard laser welding dedicated process software package.
- Precise Control: Supports time, power, and speed laser functions for precise control of laser power during both start and end phases, preventing over-welding issues.

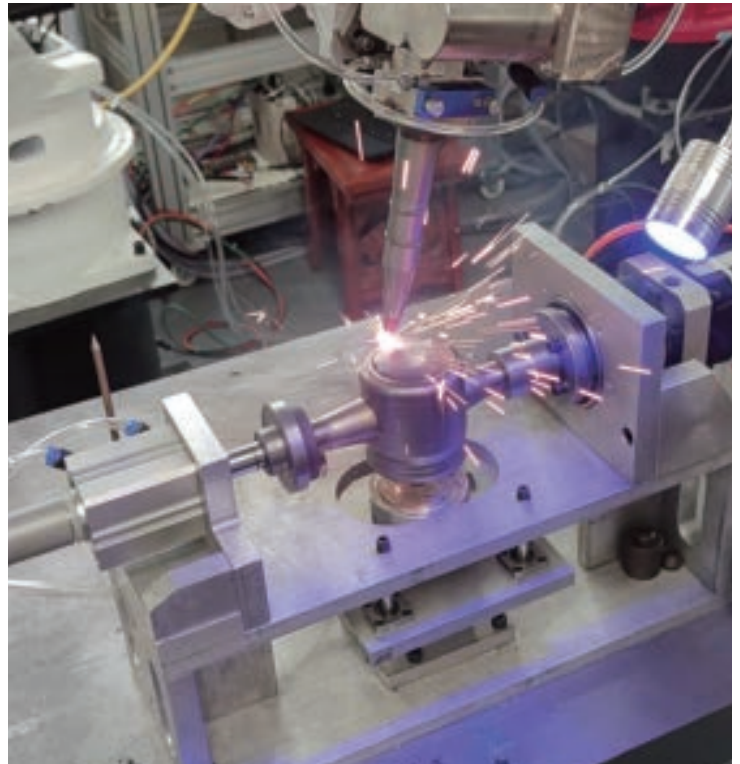

Woodworking & Glass Industry Pick and Place

Material pick and place process package



Advantages :

- Complete Process: The process package includes material probing and picking, edge-finding, and placement.
- Fast Tuning: Process software files can be saved by group number, facilitating easy process invocation and duplication.
- Reduced Recalibration: No need to recalibrate when changing material warehouses; only one point teaching for different workpiece sizes.
- Multi-Workpiece Adaptation: Meets the process requirements for different sizes and models.



Robot Applications

Flexible robot cell pick and place solution

Solution Description

Applicable Scenario: Machine tool pick and place applications in the metalworking industry

Automatic element: articulated robot, automatic storehouse, end side actuator, reverse mechanism, remote tool conversations, cloud system, etc.

Advantages:

- Automation Elements: Articulated robot, automatic material warehouse, end effector, flip table mechanism, remote tool holder, cloud system, etc.
Rapid Deployment: The trolley product features a flexible mobile design, equipped with casters and fixed brackets, enabling quick deployment.
- Fast Communication: Only one network cable or IO plug connector is needed to achieve communication between the device and the machine tool.
- Quick Tuning: During commissioning, simply test communication signals and teach pick and place points, saving on-site debugging time and quickly starting production.
Fast Line Change: According to the production plan, workstations can be quickly relocated or processing products changed to meet line change production needs.
- Non-stop Production: New workpieces can be added for processing without stopping the robot and machine tool, achieving continuous production.
- Software Features: Equipped with a torque limitation function, providing a quick-connect process package and remote tool compensation function for SYNTEC machine tool systems.



Electrical Cabinet-Free Solution

Solution Description

Models:

Y series: LS400-3, LS600-4, LS900-10

R series: LA580-4H, LA707-7H, LA906-7, LA1206-10

Advantages:

- **Wide Range:** Various robot with extensive reach to meet customized needs.
- **Cost Reduction:** Eliminates the need for robot control cabinets and some electrical components, reducing procurement and maintenance costs.
- **Quick Connection:** Supports fast connections with multiple CNC controller brands, eliminating the complex IO wiring process.
- **Simplified Structure:** Comes standard with robot, with robotelectrical controls integrated into the machine tool's electrical cabinet and pre-installed.
- **Comprehensive Service System:** A complete customer service system offering one-stop solutions and services, lowering the entry barrier for customers.

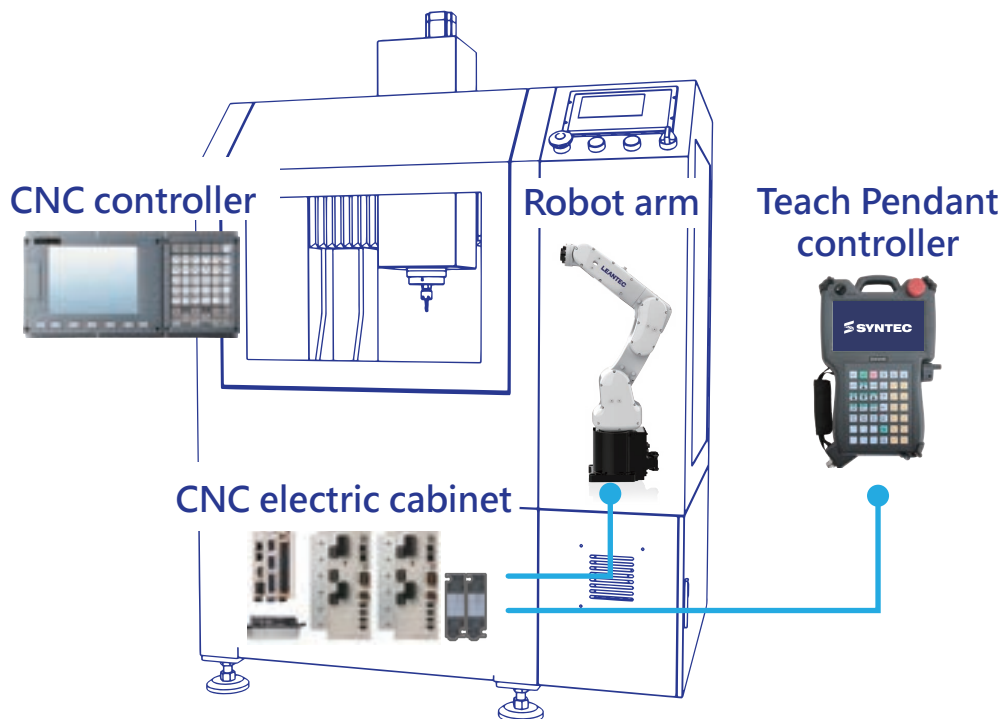

Robot Controller

Teach Pendant Controller

Item	Specifications
Language	CHT / CHS / EN
Axes	Standard 4-axis (expandable to 12-axis)
Operating mode	Touch screen, button operation
Memory	4GB, Unlimited number of programs
Servo communication	M3 bus, EtherCAT bus
External interface	USB*1
Control buttons	Control panel, Emergency stop, Mode selector switch, Safety switch, Handwheel
Cable length	10 meters
Protection rating	IP65
Ambient temperature	-10°C~50°C
Ambient humidity	-20%~90% RH, non-condensing
Dimensions (mm)	340 x 207 x 78



H Series Robot Control Cabinet

Item	H1 control cabinet	H2 control cabinet
Compatible robot model	LC800-5, LC1000-10	LC1300-15
Input power supply	1PH, 200V~240V, 50/60Hz	
Rated current at full load (A)	2.5	
Input/Output	16I, 16O, 2DA, 2AD Safety dedicated input contact	
Communication interface	Ethernet × 1(10/100Mbps)	
Dimensions (mm)	445.2 x 318.8 x 536	
Weight (kg)	18.5	





R, C, K Series Robot Control Cabinet

Item	BS20 Control box	R1 Control cabinet	CM10 Control cabinet	DM21 Control cabinet
Compatible robot model		LA580-4H LA707-7H LA906-7 LA1206-10	LA1468-10 LA1717-20 LA2000-8 LA1460-13 LA1725-20 AWA-1600C (welding) AWA-2000C (welding)	LA1813-25 LA1813-35
Input power supply	1PH, 200V~230V, 50/60Hz			3PH, 380V, 50/60Hz
Rated current at full load (A)	15	20	25	17.5
Input/Output	16I, 16O, 2DA, 1AD, 1PWM Safety dedicated input Manual brake release input	16I, 16O,	16I, 24O, 2DA, 1AD, 1PWM	16I, 24O, 2DA, 1AD, 1PWM
Communication interface	EtherCAT×1 Ethernet×1 (10/100Mbps) SRI×1 (length limit of 15m)	Ethernet×1 (10/100Mbps)		
Dimensions (mm)	330 x 330 x 90	480 x 500 x 280	580 x 460 x 870	522 x 408 x 425
Weight (kg)	7	27	70	35
Remarks			Expandable with 1 additional driver Expandable with 4 pieces of 16I or 16O modules	Expandable with 2 pieces of 16I or 16O modules

System Functions

Intuitive operation and programming

- Conversational programming, no need to learn robot languages

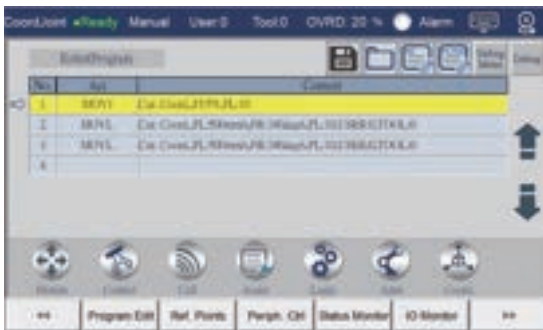

Sufficient IO commands

- Provide complete IO commands without writing any PLC on your own.
- Wait for Point I without deceleration, and output Point O during movement, which can improve the operating efficiency of the machine.



Quick implementation into practical applications

- Provide the batching tray and track tracking and workstation reservation functions
- Provide various process packages, such as welding, picking and placing, etc
- Record important points according to reference points and reuse them in the program



Easy advanced programming function

- The anti-collision area function can prevent the arm from entering a specific area to increase safety
- The dynamic anti-collision function can prevent the arm from colliding during movement
- Able to automatically pass the singular point without writing any bypassing program on your own

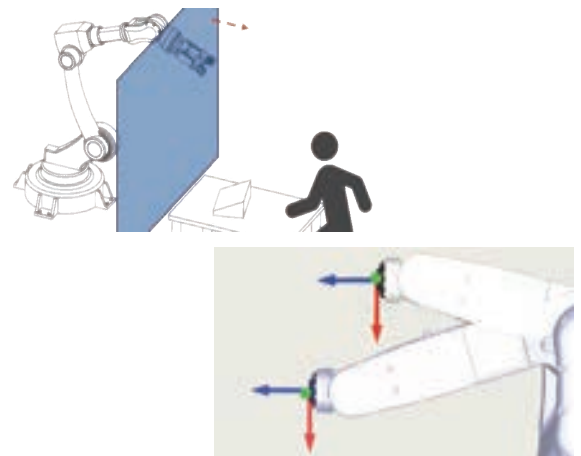

Visual Solution

Product Characteristics

- Support Modbus-TCP, EtherNet/IP communication could work with several market available visual camera use.
- Support SYNTEC visual and and others well-known brands.
- Operates through R value/IO/programming.
- It could connected to IP CAM and displayed on the controller to meet monitoring requirements.



Smart cameras



Industrial cameras



Surveillance

Measuring & Testing Solution

Product Characteristics

- Support multiple-axis synchronous motion for larger measurement range.
- Easy setup for common industrial communications. (Modbus-TCP, EtherNet/IP, etc.)
- Simple integration with other commercial vision systems.
- Generate measurement log for long-term monitoring.
- Upload data through the Internet in real time for tool compensation and remote monitoring.



MULTI-AXIS MODULE



VARIOUS MEASURING INSTRUMENTS



VISUAL MEASUREMENT METHOD



CUSTOM TABLE FORMAT



CLOUD STORAGE

LEANTEC Cloud Product

Workshop management



- Real time monitor of equipment status



- Single machine information could be more transparent

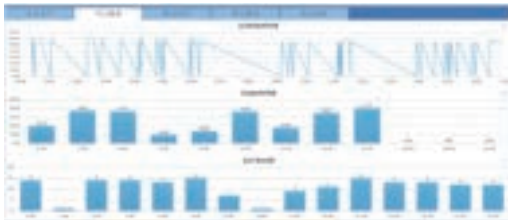

- Single machine feed rate, utilization, productivity at a glance



- Check the efficiency of equipments at any time

Processing record form



- The number of jobs reported can also be presented on the board by filtering the criteria.

Abnormal notification



- The abnormal information is alerted to the responsible personnel in time to prevent the machine from prolonged alarm and delay production.

Document delivery



- The machining process can be dispatched online to CNC.

Visualizing workshop data

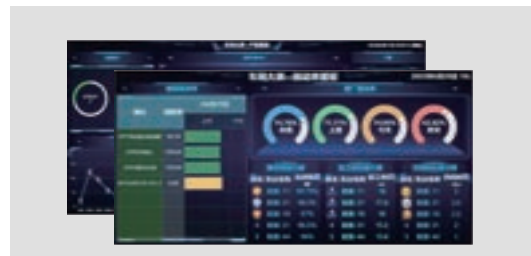

- Multiple large-screen kiosks are presented in rotation to visualize the data in workshop.



Intelligent Factory

Intelligent Factory

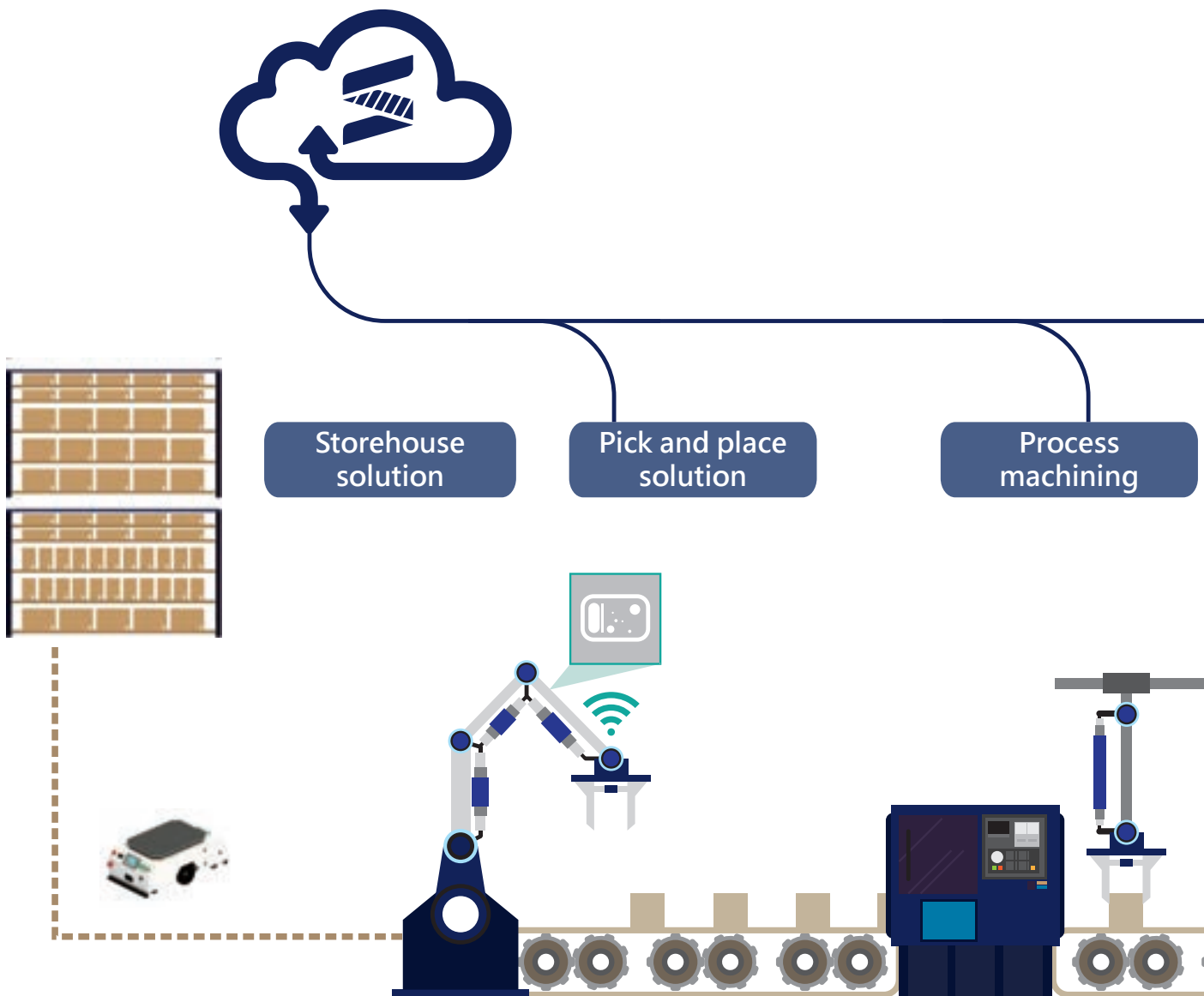



Measuring inspection

Visual solution

Production history

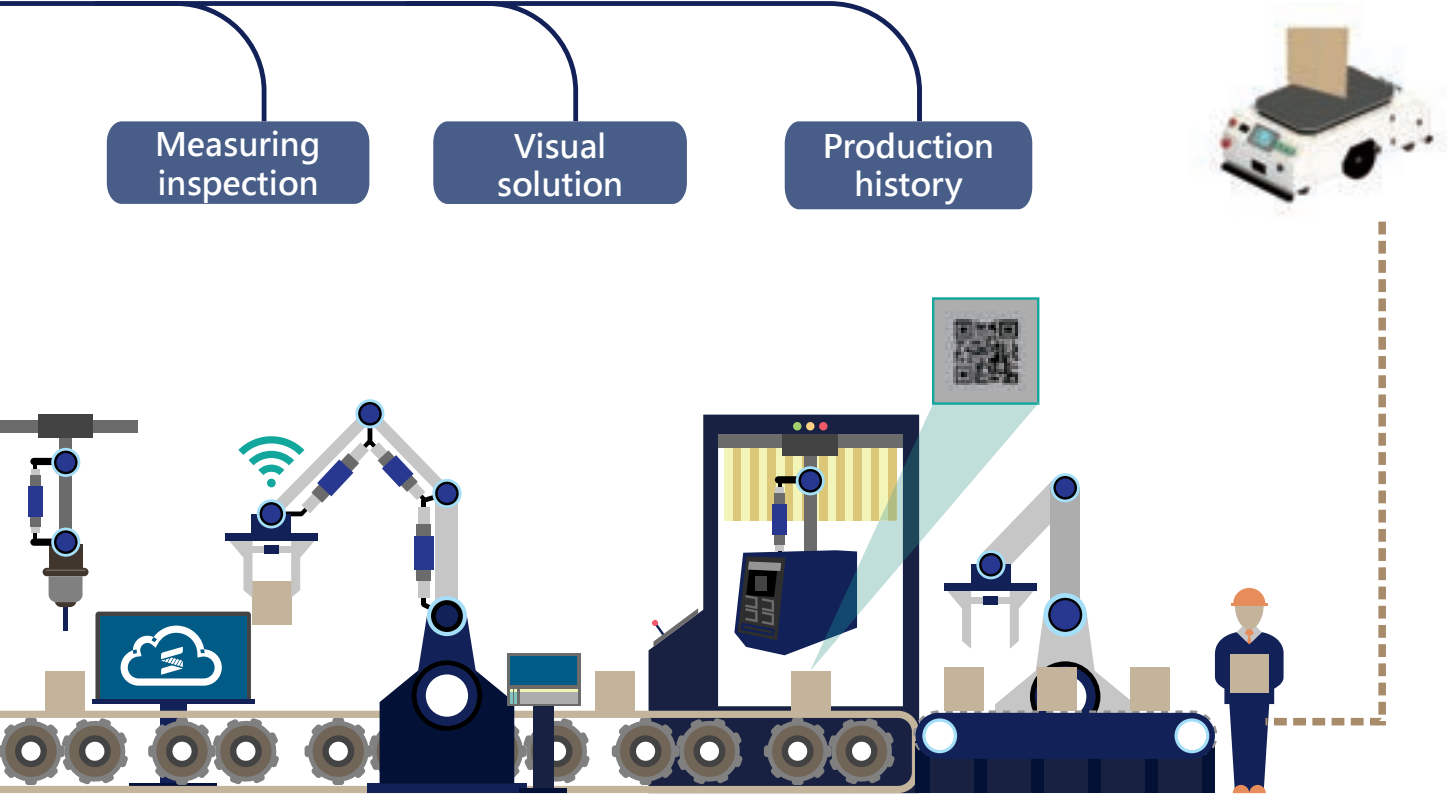

TAIWAN

Taiwan (Hsinchu)

SYNTEC Technology Co., Ltd
ADD : No.25, Yanfa 2nd Rd., East Dist.,
Hsinchu City 300, Taiwan (R.O.C.)
TEL : +886-3-6663553
FAX : +886-3-6663505
EMAIL : sales@syntecclub.com.tw

Taichung

ADD : No. 2, Jingke 3rd Rd., Nantun Dist., Taichung City 408,
Taiwan (R.O.C.)
TEL : 04-2355-0621
FAX : 04-2355-0622

SUN-CNC Co., Ltd

ADD : No. 22, Lane 428, Section 1, Fengyuan
Boulevard, Fengyuan District
TEL : +886-4-2537731
TAX : +886-4-25349224

TANLU-CNC Co., Ltd

ADD : No. 42, Jingming Road, Xitun District,
Taichung City, Taiwan (R.O.C.)
TEL : +886-4-23102626
TAX : +886-4-23102636

Kaohsiung

ADD : Rm. 1302, No.2-1, Zhuoyue Rd., Nanzi Dist., Kaohsiung City
811, Taiwan (R.O.C.)
TEL : +886-7-6011000 #7808

Tainan

ADD : No. 218, Denan Road, Rende District,
Tainan City, Taiwan (R.O.C.)
TEL : +886-6-2796707
TAX : +886-6-2796705

CHINA

Jiangsu

SYNTEC TECHNOLOGY(Suzhou)CO.,Ltd
ADD : Building B, No.9 Chunhui Road,Suzou Industrial
Park,China
TEL : 0512-69008860
FAX : 0512-65246029

SYNTEC TECHNOLOGY(Suzhou)CO.,Ltd WuXi

Office
ADD : B906, Yuye Network Building, 68 Exploration
Road, Huishan District, Wuxi City, Jiangsu Province,
China
TEL : 15295664580

SYNTEC TECHNOLOGY(Suzhou)CO.,Ltd

Changzhou Office
ADD : Room 2217, Yatai Fortune Center, No. 1
Huayuan Street, Hutang Town, Wujin District,
Changzhou City, Jiangsu Province, China
TEL : 18168828572

SYNTEC TECHNOLOGY(Suzhou)CO.,Ltd

Xuzhou Branch
ADD : Room 1503, South of Territorial Sea Economic
Building, No. 66, Kunpeng Road, Xuzhou Oceanomic
Development Zone, Jiangsu Province, China
TEL : 13656201020

SYNTEC TECHNOLOGY(Suzhou)CO.,Ltd

Nanjing Branch
ADD : Room 712, Research Building 1, Lianggang
Park, 117 Suyuan Avenue, Jiangning District, Nanjing
City, Jiangsu Province, China
TEL : 025-52717702
FAX : 025-52717710

SYNTEC TECHNOLOGY(Suzhou)CO.,Ltd

NanTong Branch
ADD : Room T3-1301, No. 108, Gangzha District,
North Street, Nantong City, Jiangsu Province, China
TEL : 0513-89077025
FAX : 0513-89072057

SYNTEC TECHNOLOGY(Suzhou)CO.,Ltd

NanTong Branch Yanchen Office
ADD : Room 401, building 13, phase 9, Zhongnan
Century City, Yandu District, Yancheng City, Jiangsu
Province
TEL : 18625235150

Shaanxi

SYNTEC TECHNOLOGY(Suzhou)CO.,Ltd XiAn
Branch
ADD : Room 1_1328, Building 4, Yicui Garden I
Duhui, No. 10, South Tangyan Road, Xi'an
High-tech Zone
TEL : 029-88287423

SYNTEC TECHNOLOGY(Suzhou)CO.,Ltd Baoji

Office
ADD : Room 1702, Unit 3, Building 8, Dongling Xinhiji,
Binhe North Road, Jintai District, Baoji, Shaanxi
Province, China

AROUND THE WORLD

Malaysia

MYSYNTEC TECHNOLOGY SDN BHD
ADD : 16, Jalan Astana 1F, Bandar Bukit Raja, 41050 Klang,
Selangor, Malaysia.
TEL : +603-33115887
EMAIL : sales.malaysia@syntecclub.com

Thailand

SYNTEC TECHNOLOGY CO. LTD (Thailand)
ADD : 78/38 Kheha Romkiao Rd., Khlong Song Ton Nun,
Lat Krabang,Bangkok, 10520
TEL : +662-006-5738
EMAIL : thanawai@syntecclub.com.tw

Vietnam

SYNTEC VIET NAM TECHNOLOGY CO., LTD
ADD : No. 18, A4 Street, Ward 12, Tan Binh District,
Ho Chi Minh City, Viet Nam
TEL : +84938332829
FAX : +842822535556
EMAIL : andyng@vmsyntec.com.vn

India

SYNTEC TECHNOLOGY INDIA PVT.LTD
ADD : Champaka building, P-6C,2nd floor, peenya industrial
area Near peenya police station Bangalore-560058
TEL : +91-9916146577
E-mail : raghavendra.naik@syntecclub.com

Turkey

SYNTEC TEKNOLOJİ LTD (Istanbul)
ADD : Küçükbakkalköy Mah. Vedat Günyol Cd. Defne Sok.
No:1 D:1502 Flora Residence,34750 Atasehir/Istanbul, Türkiye
TEL : +90-216-2662475
EMAIL : info@syntec-turkey.com

USA (South California)

USA SYNTEC ECHNOLOGY, INC (South California)
ADD : 2841 Saturn St, #D, Brea, CA 92821
TEL : +1909-551-0187
EMAIL : info@syntecamerica.com

Indonesia

PT. OTOMASI BERSAMA INDONESIA
ADD : Ruko Arcadia Mataram Blok B, No 15, Kelurahan
Cibatu, Kecamatan Cikarang selatan, 17530, Indonesia
TEL : +6221 2210 4832
EMAIL : yulius@otomasi.co

Korea

AISYNTECH (Service Partner)
ADD : 312Ho 103Dong 88, Sinwon-ro, Yeongtong-gu, Suwon-si,
Gyeonggi-do, 16681, Rep. of KOREA
TEL : +82 70-8615-1134
EMAIL : ttechvt100@gmail.com

Guangdong

SYNTEC TECHNOLOGY(Suzhou)CO.,Ltd GuangDong
Branch
ADD : Factory 201or 301, Building A, No.10 Nanjiang
Third Road, Zhuijiang Street, Nansha District, Guangzhou
City
TEL : 020-39089367
FAX : 020-39089791

SYNTEC TECHNOLOGY(Suzhou)CO.,Ltd DongGuan

Branch
ADD : 0769-81661ing 1, Mobile Group, No. 522, Zhen
'an East Road, Chang 'an Town, Dongguan City,
Guangdong Province, China
TEL : 0769-81660318

SYNTEC TECHNOLOGY(Suzhou)CO.,Ltd GuangZhou

Branch
ADD : Room 404, Building 2, Seven Friendship Building,
No. 8 Luojiajun Section, Fuyi Road, Dalong Street,
Panyu District, Guangzhou City, Guangdong Province
TEL : 020-34583040
FAX : 020-34583220

SYNTEC TECHNOLOGY(Suzhou)CO.,Ltd ChangPing

Branch
ADD : Floor 5, Huilong Building, No. 8, Zhanqian 1st
Road, Banshi Village, Changping Town, Dongguan City,
Guangdong Province, China
TEL : 0769-82826002
FAX : 0769-82826820

SYNTEC TECHNOLOGY(Suzhou)CO.,Ltd ShenZhen

Branch
ADD : 406, Block E, Haowei new material industrial
park, No. 8, Qinglan 1st Road, Zhukeng community,
Longlian street, Pingshan District, Shenzhen,
Guangdong
TEL : 0755-84320380
FAX : 0755-84559490

SYNTEC TECHNOLOGY(Suzhou)CO.,Ltd JiangMen

Branch
ADD : Room 02, 7th Floor, Torch Building, Hi-Tech
Zone, 288 Jinou Road, Jianghai District, Jiangmen City,
Guangdong Province - China
TEL : 0750-3762143

Henan

SYNTEC TECHNOLOGY(Suzhou)CO.,Ltd LuoYang
Branch
ADD : Room 704, Runsheng Building, Intersection of
Heluo Road and Sanshan Road, Hi-tech Zone, Luoyang,
Henan Province, China
TEL : 0379-65110352
FAX : 0379-65110352

SYNTEC TECHNOLOGY(Suzhou)CO.,Ltd

ShiJiaZhuang Office
ADD : 4-3-801, Reyli Community, No. 8 Huaxing Road,
Qiaoxi District, Shijiazhuang City, Hebei Province, China
TEL : 18622728669
FAX : 0379-65110352

Fujian

SYNTEC TECHNOLOGY(Suzhou)CO.,Ltd XiaMen
Branch
ADD : Floor 3, No. 2, Jixiang West Road, Xinmin Town,
Tong'an District, Xiamen City, Fujian Province
TEL : 0592-7191901
FAX : 0592-7220536

Zhejiang

SYNTEC TECHNOLOGY(Suzhou)CO.,Ltd HangZhou
Branch
ADD : 1202, Unit 2, Building 1, Dikai Building, No.471
Jincheng Road, Xiaoshan District, Hangzhou City,
Zhejiang Province, China
TEL : 0571-82751187

SYNTEC TECHNOLOGY(Suzhou)CO.,Ltd HangZhou

Branch Jinhua Office
ADD : Room G204, No. 1729, Dongshi North Street,
Xinshi street, Wucheng District, Jinhua City, Zhejiang
Province
TEL : 1599-0026533

SYNTEC TECHNOLOGY(Suzhou)CO.,Ltd WenZhou

Branch
ADD : 1205-3, Honghai building, Ouhai District,
Wenzhou City, Zhejiang Province
TEL : 0577-86158619

SYNTEC TECHNOLOGY(Suzhou)CO.,Ltd NingBo

Branch
ADD : Room 1207, Ivy league Building, No.262, Lane
416, Zhaohui Road, Jiangdong District, Ningbo City,
Zhejiang Province, China
TEL : 0574-87750305

SYNTEC TECHNOLOGY(Suzhou)CO.,Ltd WenLing

Branch
ADD : Room 509, Haocheng Service Building, No. 838,
Wanchang Middle Road, Chengdong Street, Wenling
City, Taizhou City, Zhejiang Province, China
TEL : 0576-86138372
FAX : 0576-86119106

SYNTEC TECHNOLOGY(Suzhou)CO.,Ltd YuHuan

Office
ADD : Room 302, Unit 2, Building 1, Hualong Times
Square, 226 Provincial Road, Chunmen Town, Yuhuan
County, Taizhou City, Zhejiang Province, China
TEL : 13088636567

Chongqing

SYNTEC TECHNOLOGY(Suzhou)CO.,Ltd ChongQing
Branch
ADD : 1007, Building 4, No.62, East Section of Taishan
Avenue, Yubei District, Chongqing
TEL : 023-67913296
FAX : 023-67634382

SYNTEC TECHNOLOGY(Suzhou)CO.,Ltd ChengDu

Office
ADD : ADD : Room102, Unit 1, Building 24, Jiashaoye
Modern City, No.898, Section 2, Xingxing Road,
Dongsheng Street, Shuangliu District, Chengdu City,
Sichuan Province, China
TEL : 18302866229

LEANTEC Intelligence CO., LTD.

No.25, Yanfa 2nd Rd., East Dist.,
Hsinchu City 300, Taiwan

☎ 886-3-6663553

☎ 886-3-6663505

✉ sales@syntecclub.com.tw

2F., No.2, Jingke 3rd Rd.,
Nantun Dist.,Taichung City 408

☎ 886-4-23550621

☎ 886-4-23550621

✉ sales@leantec.com.tw

Suzhou LEANTEC Intelligence Co., Ltd.

Building B, No.9 Chunhui Road,Suzou
Industrial Park,China

☎ 86-512-69008860

☎ 86-512-65246029

✉ service@syntecclub.com.cn



<https://www.leantec.com.tw/default.aspx>

Specifications and external appearance are subject to change without notice.

Copyright © 2024 LEATEC Inc. All rights reserved

Catalog Number : 2024-V1